

*Replacement Parts Diagram  
332H & 348H Hole Digger  
Equipped With Honda GXV160 Engine*

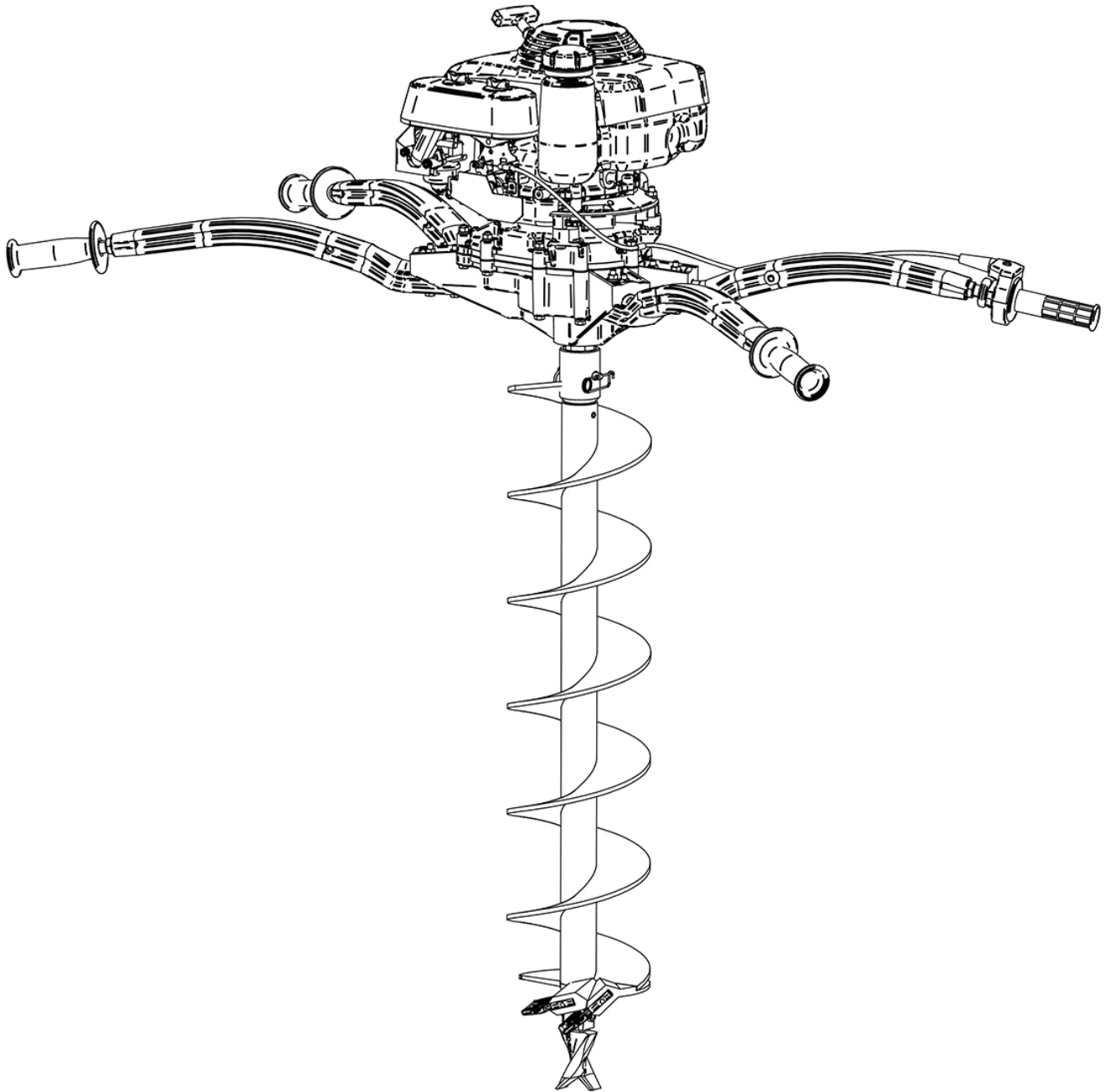

## Replacement Parts Diagram Transmission Cover Assembly 332H & 348H Hole Digger [Beginning with Serial Number 174809]

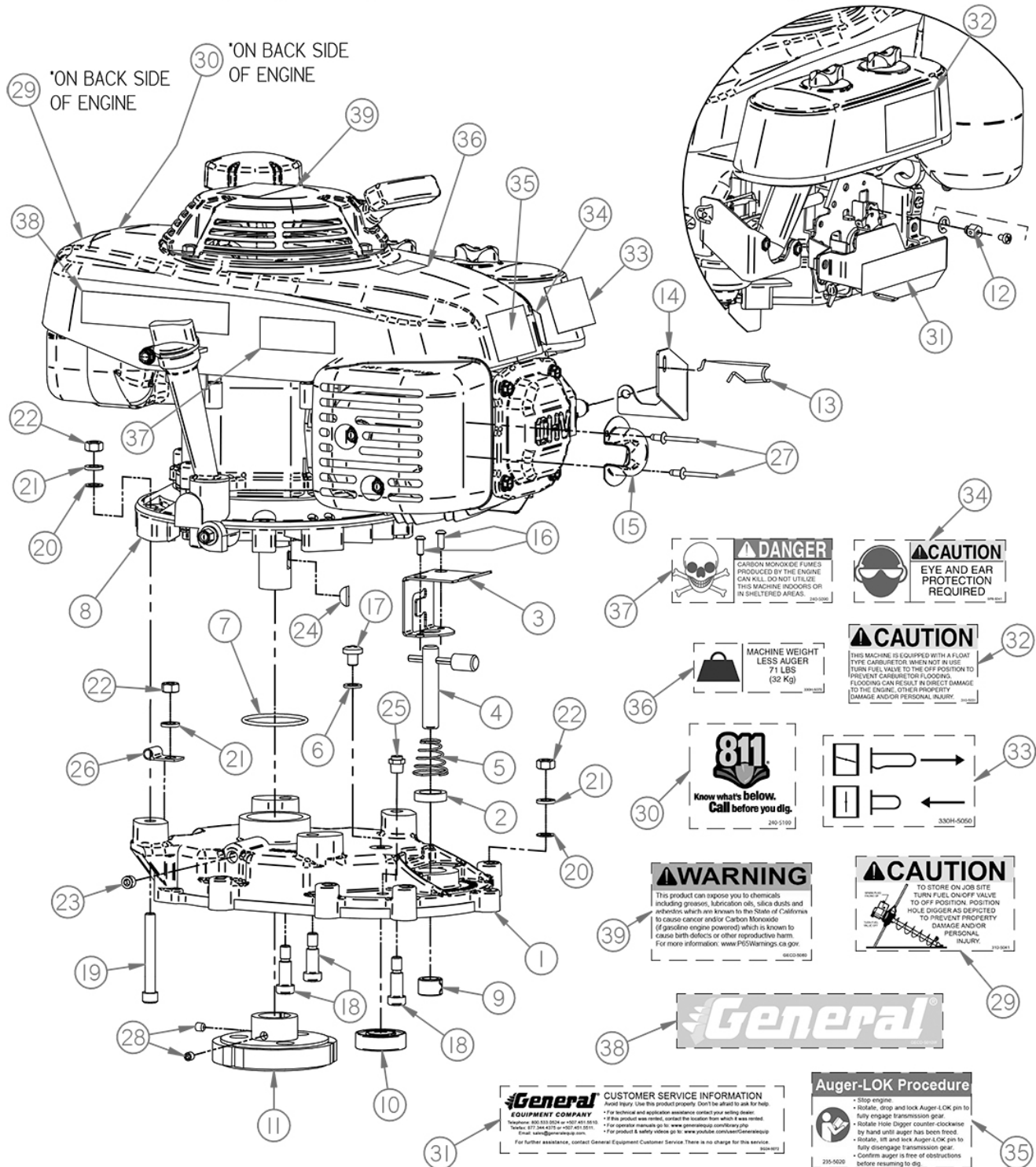

## Replacement Parts Diagram Transmission Cover Assembly 332H & 348H Hole Digger [Beginning with Serial Number 174809]

Reference Number	Part Number	Description	Quantity
1	332-0130A	Assembly, Cover, Transmission, (Includes Ref. 9 & 10)	1
2	471442	Seal, Oil	1
3	235-0230	Plate, Pin, Lock	1
4	235-0220	Assembly, Pin, Lock	1
5	235-0110	Spring, Pin, Lock	1
6	330H-0200	Washer, Nylon	1
7	330H-0020	Ring, O Type	1
8	GXV160UH2N5AH-BLK	Engine, Honda, GXV160	1
9	235-0140	Bushing, Spring-Type	1
10	6203-2RS-12	Bearing, Ball	1
11	330H-0175	Assembly, Rotor/Shoe, Clutch, (Includes Ref. 28)	1
12	330-0320	Assembly, Swivel	1
13	16611-ZG9-U80	Rod, Choke	1
14	17954-ZG9-U80	Bracket, Choke	1
15	330H-0040	Deflector, Exhaust, Gxv160	1
16	55030400	BHSCS, #10-24 X 1/2, ZY	2
17	37050300	PHMS, 5/16-18 X 3/8, ZY	1
18	62060601	Bolt, Shoulder, 3/8 X 3/4	3
19	60052000	SHCS, 5/16-18 X 2-1/2, ZY	1
20	AN-960-516L	Washer, Flat, 5/16, ZY	7
21	16050000	Washer, Lock, 5/16, ZY	8
22	18050000	Nut, Hex, 5/16-18, ZY	8
23	74020201	Plug, PTF, 1/8-27	1
24	6	Key, Woodruff, 5/32 X 5/8	1
25	5677	Valve, Relief	1
26	COV-0411	Clamp	1
27	46030100	Rivet, Pop, 3/16 X 1/8, SS	2
28	31040201	Screw, Set, 1/4-28 X 1/4, PF	2
29	310-5041	Decal, Storage	1
30	240-5100	Decal, 811	1
31	SG24-5072	Decal, Assistance	1
32	310-5031	Decal, Carb Off	1
33	330H-5050	Decal, Choke	1
34	SP8-5041	Decal, Caution, Eye/Ear	1
35	235-5020	Decal, Lock, Auger	1
36	330H-5070	Decal, Weight	1
37	240-5090	Decal, Danger	1
38	ZDBRPA265H01	Decal, BRPA265H, (Used on BRPA265H Only)	1
	ZDBRPA270H01	Decal, BRPA270H, (Used on BRPA270H Only)	1
39	GECD-5060	Decal, Warning, Prop 65	1

*Replacement Parts Diagram  
Transmission Case Assembly  
332H & 348H Hole Digger  
[Beginning with Serial Number 174809]*

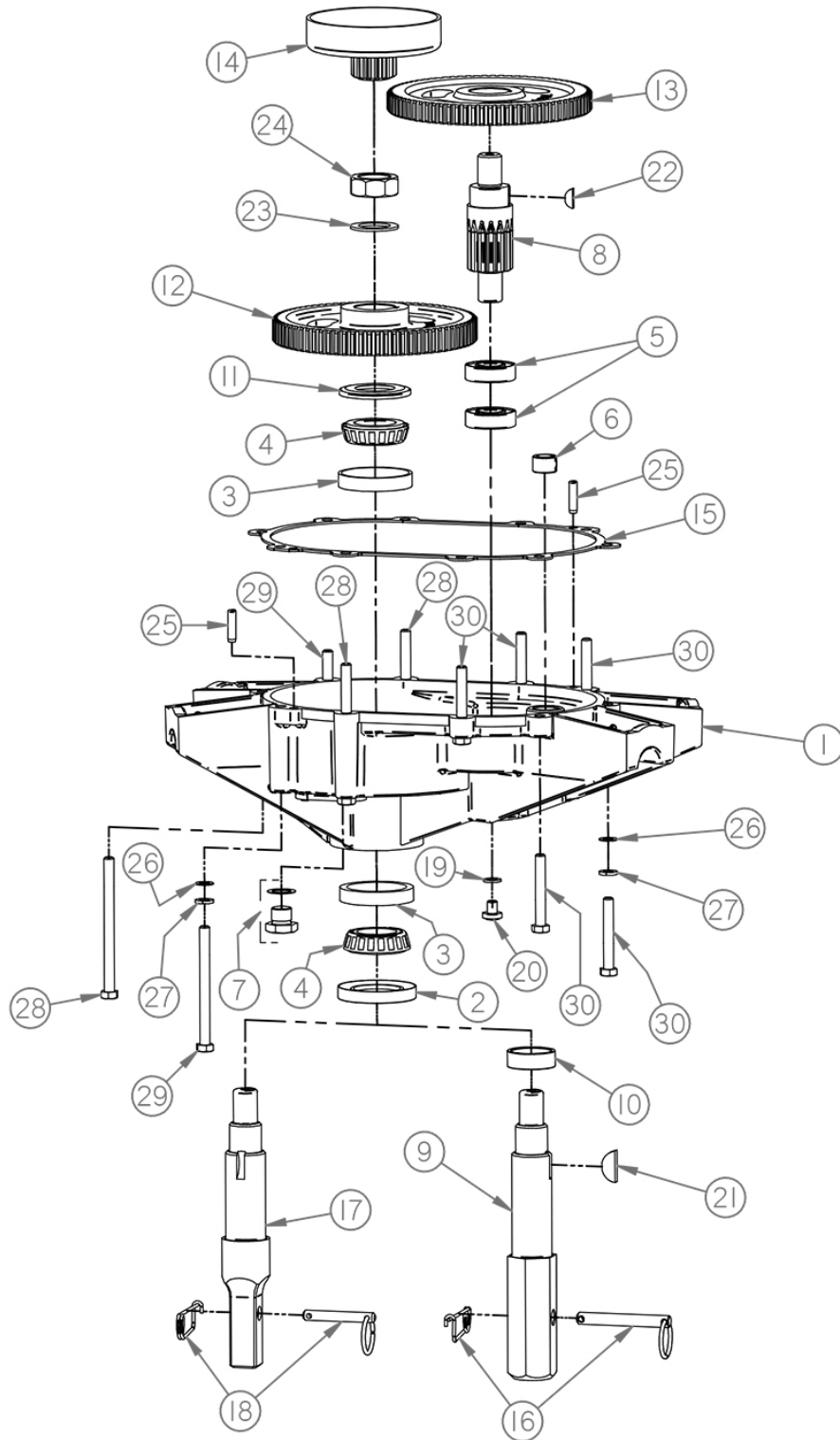

*Replacement Parts Diagram  
 Transmission Case Assembly  
 332H & 348H Hole Digger  
 [Beginning with Serial Number 174809]*

Reference Number	Part Number	Description	Quantity
1	332-0120A	Assembly, Case, Transmission, (Includes Ref. 3, 5 & 6)	1
2	471820	Seal, Oil	1
3	08231	Cup, Bearing	2
4	08125G	Cone, Bearing	2
5	6203-2RS-12	Bearing, Ball	2
6	235-0140	Bushing, Spring-Type	1
7	50100800A	Plug, Drain, Oil, W/Gasket	1
8	332-0310	Gear, Pinion, Secondary	1
9	332-0330A	Shaft, Drive, 1.38HEX, (Used on 332H, Includes Ref. 10)	1
10	332-0330-010	Bushing, Shaft, Drive	1
11	0812508231B-AV	Ring, Nilos	1
12	332-0350	Gear, Secondary	1
13	7034	Gear, Primary	1
14	3516	Drum, Clutch, W/Pinion	1
15	332-0100PAK2	Pak2, Gasket, Transmission	1
16	2121PAK3	Pak3, Pin, Auger, .375D	1
17	348-0330	Shaft, Drive, .88SQ, (Used on 348H)	1
18	2021PAK3	Pak3, Pin, Auger, .312D	1
19	330H-0200	Washer, Nylon	1
20	37050300	PHMS, 5/16-18 X 3/8, ZY	1
21	15	Key, Woodruff, 1/4 X 1	1
22	6	Key, Woodruff, 5/32 X 5/8	1
23	85160000	Bushing, Machine, 1.0NR	1
24	40160001	Nut, Jam, Hex, 1-14, Z	1
25	51040800	Pin, Dowel, 1/4 X 1	2
26	AN-960-516L	Washer, Flat, 5/16, ZY	9
27	16050000	Washer, Lock, 5/16, ZY	10
28	15053400	HHCS, 5/16-18 X 4-1/4, ZY	3
29	15053000	HHCS, 5/16-18 X 3-3/4, ZY	2
30	15051800	HHCS, 5/16-18 X 2-1/4, ZY	5



**Replacement Parts Diagram  
 Throttle Handle Assembly  
 332H & 348H Hole Digger  
 [Beginning with Serial Number 174809]**

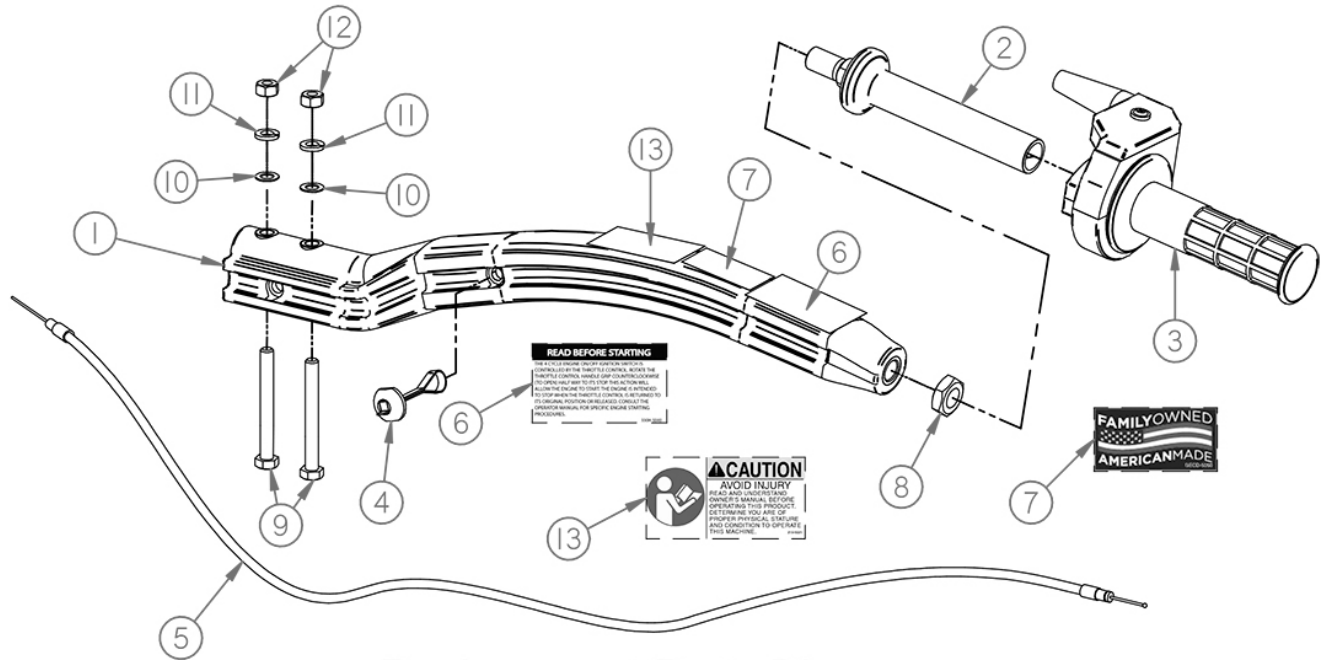

**Replacement Parts Diagram  
 Operator Handle Assembly  
 332H & 348H Hole Digger  
 [Beginning with Serial Number 174809]**

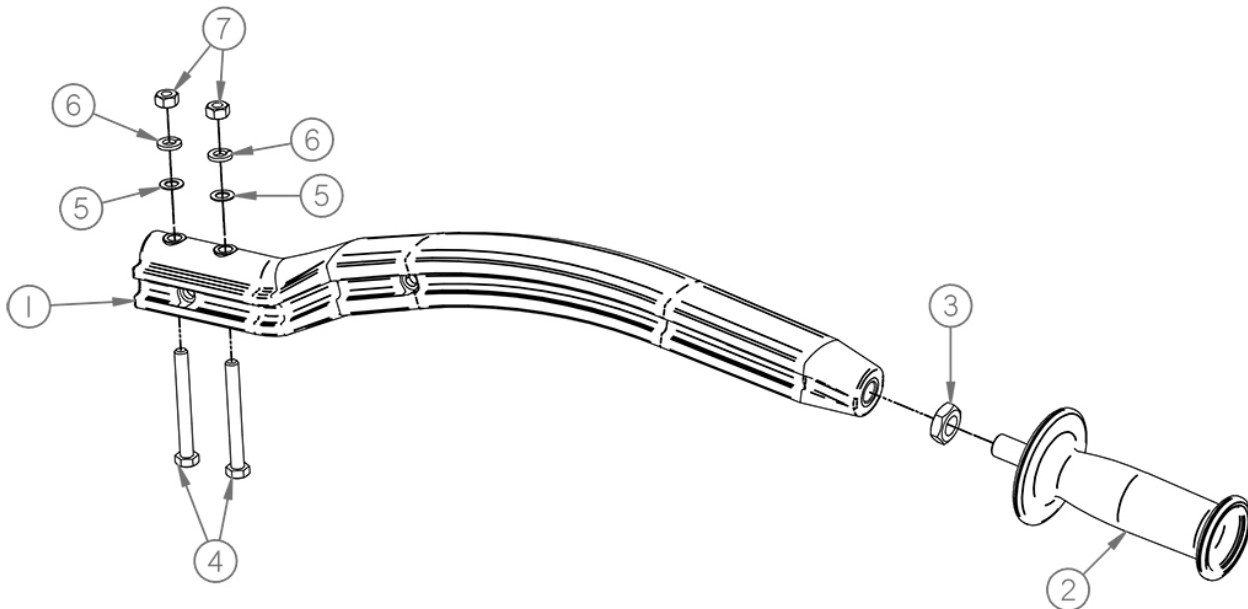

*Replacement Parts Diagram  
 Throttle Handle Assembly  
 332H & 348H Hole Digger  
 [Beginning with Serial Number 174809]*

Reference Number	Part Number	Description	Quantity
1	235-0150	Handle, Throttle	1
2	235-0250	Grip, Handle, Throttle	1
3	310-0030	Assembly, Control, Throttle	1
4	235-0370	Tie, Cable, Throttle	1
5	310-0081PAK2	Pak2, Assy, Cable, Throttle	1
6	330H-5040	Decal, Ignition	1
7	GECD-5050	Decal, Family Owned, American	1
8	40090001	Nut, Jam, Hex, 9/16-18, ZY	1
9	15052200	HHCS, 5/16-18 X 2-3/4, ZY	2
10	AN-960-516L	Washer, Flat, 5/16, ZY	2
11	16050000	Washer, Lock, 5/16, ZY	2
12	18050000	Nut, Hex, 5/16-18, ZY	2
13	210-5021	Decal, Caution, Avoid Injury	1

*Replacement Parts Diagram  
 Operator Handle Assembly  
 332H & 348H Hole Digger  
 [Beginning with Serial Number 174809]*

Reference Number	Part Number	Description	Quantity
1	235-0090	Handle, Operator	1
2	235-0240	Grip, Handle, Operator	1
3	40090001	Nut, Jam, Hex, 9/16-18, ZY	1
4	15052200	HHCS, 5/16-18 X 2-3/4, ZY	2
5	AN-960-516L	Washer, Flat, 5/16, ZY	2
6	16050000	Washer, Lock, 5/16, ZY	2
7	18050000	Nut, Hex, 5/16-18, ZY	2

## Replacement Parts Diagram PN: 310-0030 Throttle Control Assembly For Use With 300 Series Hole Diggers

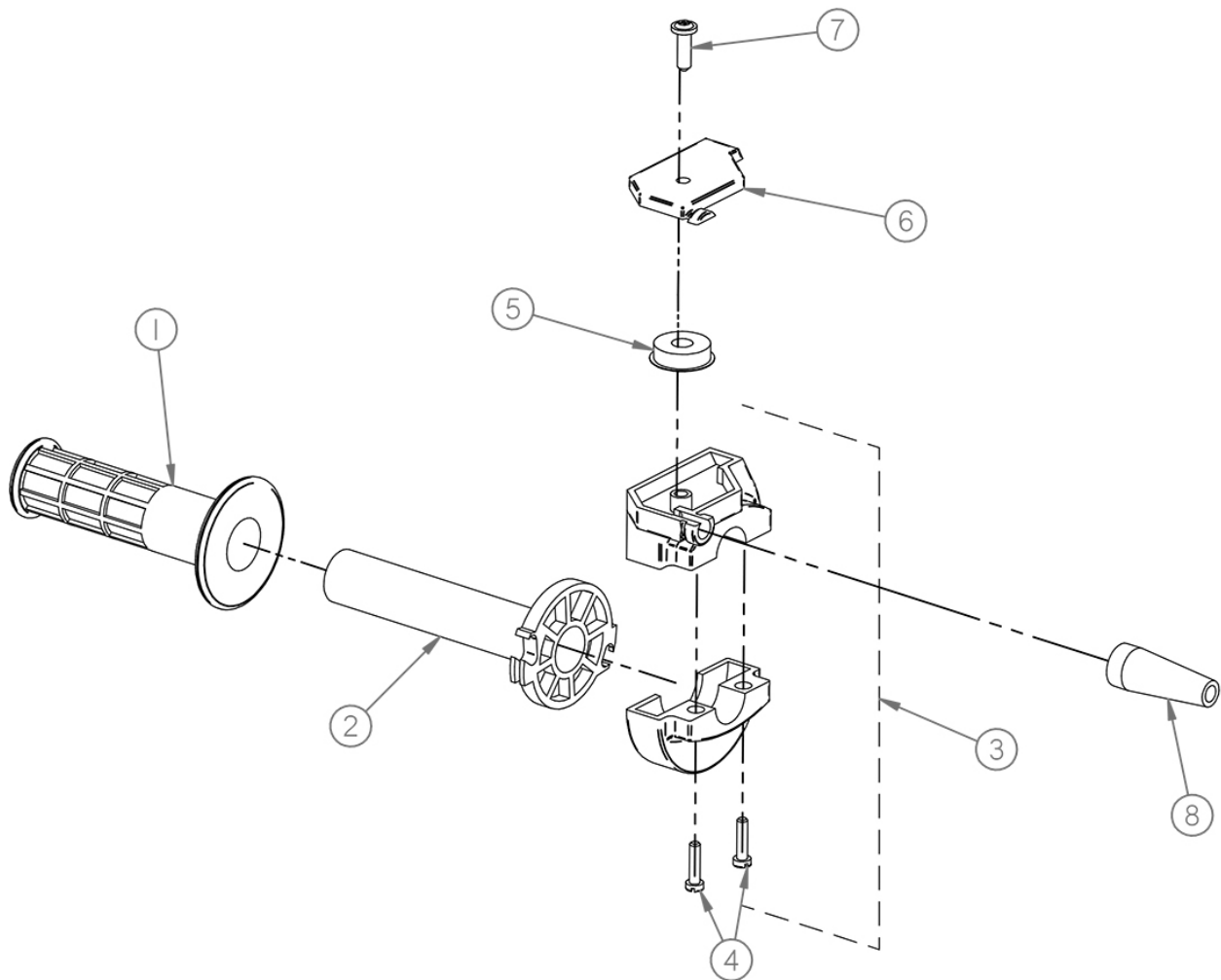

Reference Number	Part Number	Description	Quantity
1	310-0020-030	Grip, Throttle	1
2	310-0030-020-A	Tube, Throttle, W/Grip, (Includes Reference 1)	1
3	310-0030-010-A	Assembly, Body, W/Screws, (Includes Reference 4)	1
4	310-0030-040	Screw, Cheesehead, M5-.8 X 20	2
5	310-0030-070	Sheave, Roller	1
6	310-0030-060	Cover, Top	1
7	310-0030-050	Screw, Self-Tapping	1
8	310-0020-080	Boot, Rubber	1



## Replacement Parts Diagram 4400 Series Augers (2 Thru 4 Inch Diameter) For Use With 332H Hole Digger

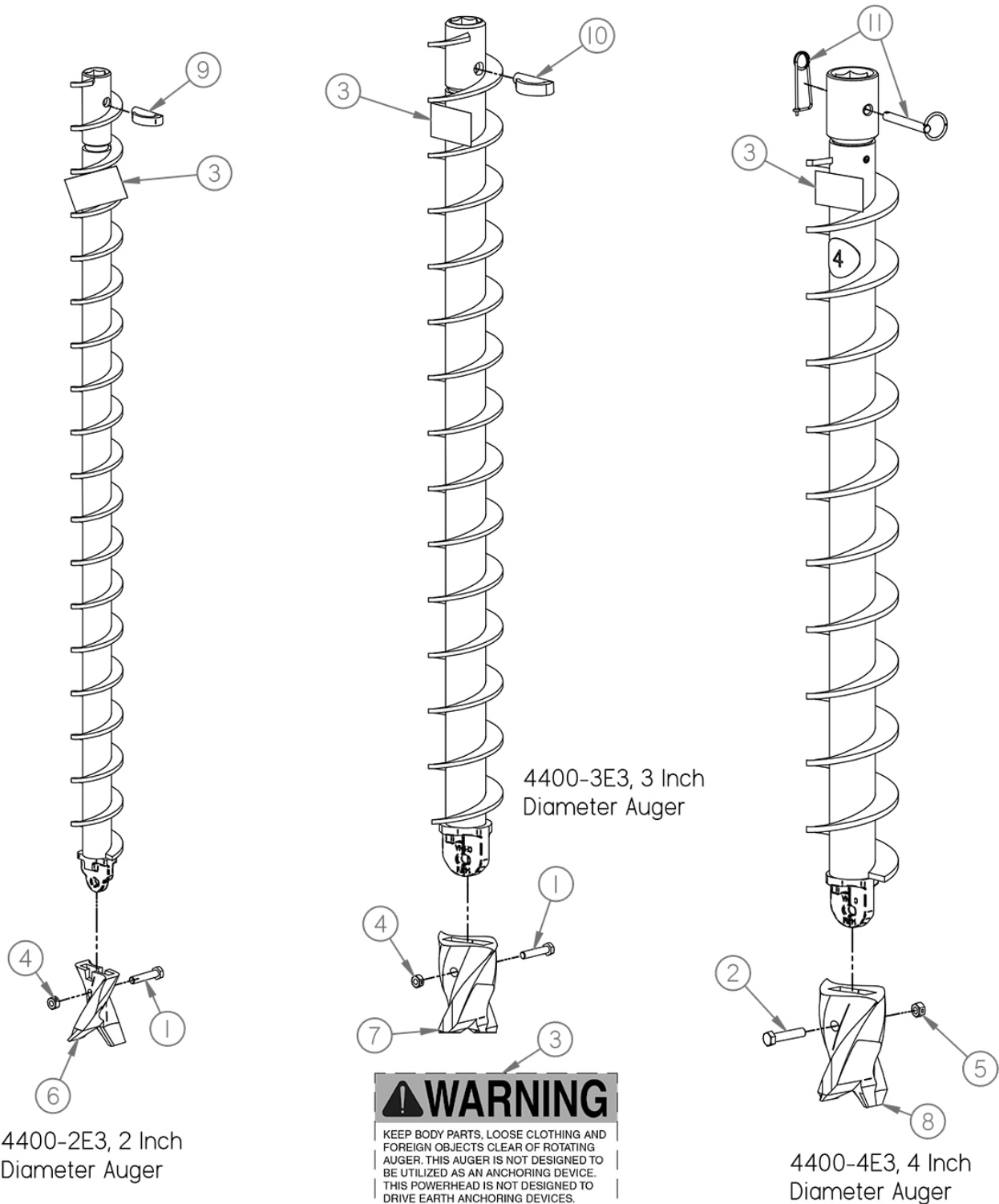

*Replacement Parts Diagram  
 4400 Series Augers (2 Thru 4 Inch Diameter)  
 For Use With 332H Hole Digger*

Reference Number	Part Number	Description	Application	Quantity
1	15051200	HHCS, 5/16-18 X 1-1/2, ZY	4400-2E3 Thru 4400-3E3	1
2	15061400	HHCS, 3/8-16 X 1-3/4, ZY	4400-4E4	1
3	233-5093	Decal, Caution, Clear Rotating	All Augers	1
4	52050000	Nut, Lock, 2-Way, 5/16-18, ZY	4400-2E3 Thru 4400-3E3	1
5	52060000	Nut, Lock, 2-Way, 3/8-16, ZY	4400-4E3	1
6	SB25PAK3	Pak3, Bit, Screw, Auger, (Includes Reference 1 & 4)	4400-2E3	1
7	SB35	Bit, Screw, Auger, (Includes Reference 1 & 4)	4400-3E3	1
8	SB45	Bit, Screw, Auger, (Includes Reference 2 & 5)	4400-4E3	1
9	DP-2	Pin, Drive	4400-2E3	1
10	DP-3	Pin, Drive	4400-3E3	1
11	2121PAK3	Pak3, Pin, Auger, .375D	4400-4E3	1

## Replacement Parts Diagram 4400 & 4450 Series Augers (6 Thru 18 Inch Diameter) 1-3/8 Inch Hexagon Drive Connection For Use With 332H Hole Digger

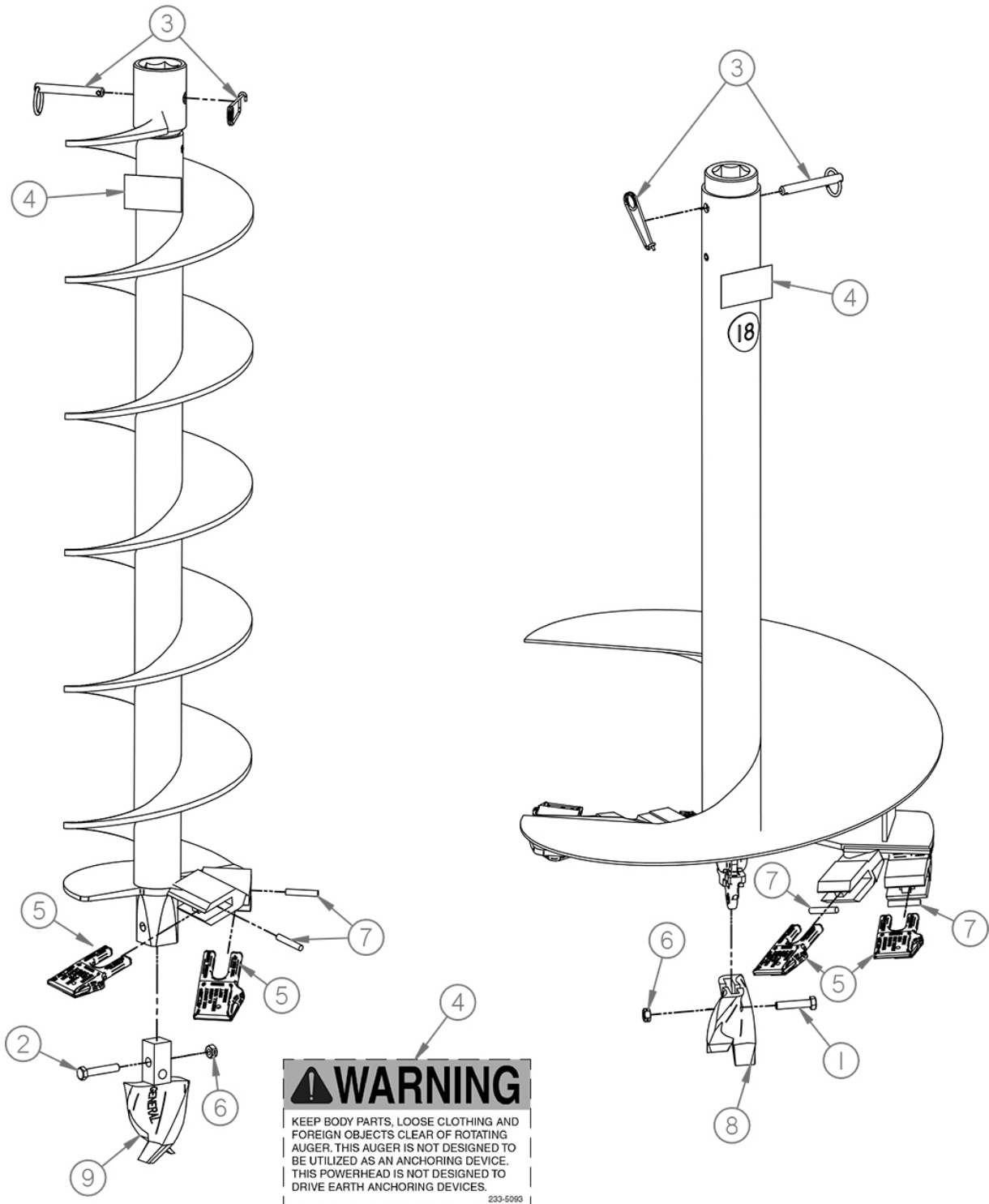

*Replacement Parts Diagram  
 4400 & 4450 Series Augers (6 Thru 18 Inch Diameter)  
 1-3/8 Inch Hexagon Drive Connection  
 For Use With 332H Hole Digger*

Reference Number	Part Number	Description	Application	Quantity
1	15051200	HHCS, 5/16-18 X 1-1/2, ZY	4400-14E3 Thru 4400-18P	1
2	15051400	HHCS, 5/16-18 X 1-3/4, ZY	4450-6E3 Thru 4450-12E3	1
3	2121PAK3	Pak3, Pin, Auger, .375D	4400-6E3 Thru 4400-18P	1
4	233-5093	Decal, Caution, Clear Rotating	All Augers	1
5	35HFCPAK7	Pak7, Tooth, Dirt, Hardfaced, (Includes 7 Each PN: RL, Lock, Rubber)	4450-6E3 Thru 4400-18P	As Req.
6	52050000	Nut, Lock, 2-Way, 5/16-18, ZY	4450-6E3 Thru 4400-18P	1
7	RLPAK21	Pak21, Lock, Rubber	4450-6E3 Thru 4400-18P	As Req.
8	SB25PAK3	Pak3, Bit, Screw, Auger, (Includes Ref. 1 & 6)	4400-14E3 Thru 4400-18P	1
9	SB26PAK3	Pak3, Bit, Screw, Auger, (Includes Ref. 2 & 6)	4450-6E3 Thru 4450-12E3	1

*Replacement Parts Diagram  
4400 Series Couplers  
(Use With 4400-2E3 and 4400-3E3 Augers)  
For Use With 332H & 348H Hole Digger*

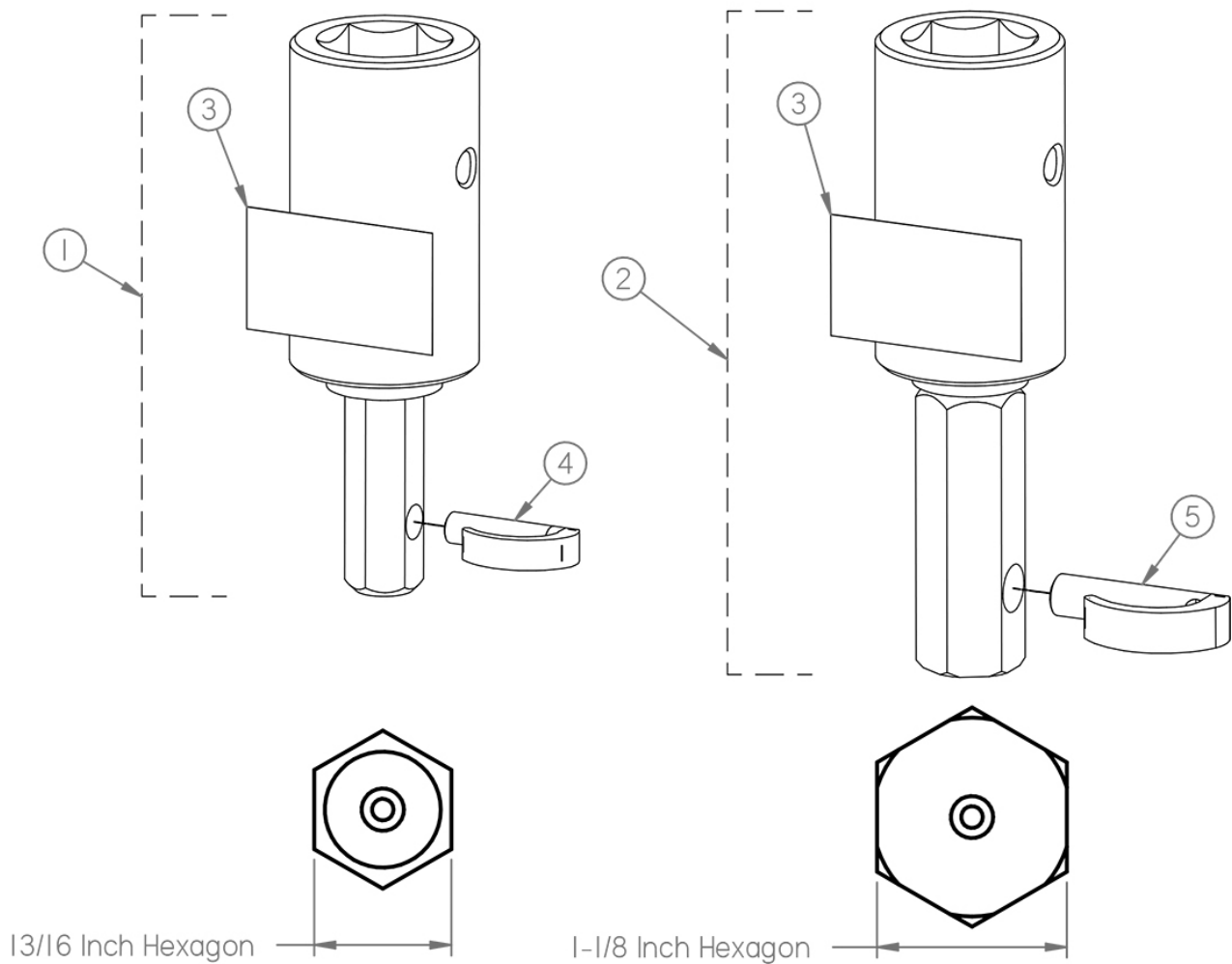

3

**⚠ WARNING**

KEEP BODY PARTS, LOOSE CLOTHING AND FOREIGN OBJECTS CLEAR OF ROTATING AUGER. THIS AUGER IS NOT DESIGNED TO BE UTILIZED AS AN ANCHORING DEVICE. THIS POWERHEAD IS NOT DESIGNED TO DRIVE EARTH ANCHORING DEVICES.

233-5093



*Replacement Parts Diagram  
 4400 Series Couplers  
 (Use With 4400-2E3 and 4400-3E3 Augers)  
 For Use With 332H Hole Digger*

Reference Number	Part Number	Description	Quantity
1	4400-2CLR	CPLR, 1-3/8 Box To 13/16 Pin, (Includes Ref. 3 & 4) (For Use With 4400-2E3 Auger)	1
2	4400-3CLR	CPLR, 1-3/8 Box To 1-1/8 Pin, (Includes Ref. 3 & 5) (For Use With 4400-3E3 Auger)	1
3	233-5093	Decal, Caution, Clear Rotating	1
4	DP-2	Pin, Drive	1
5	DP-3	Pin, Drive	1

*Replacement Parts Diagram  
 PSD & PLDBH Series Augers (4 Thru 12 Inch Diameter)  
 7/8 Inch Square Drive Connection  
 For Use With 348H Hole Digger*

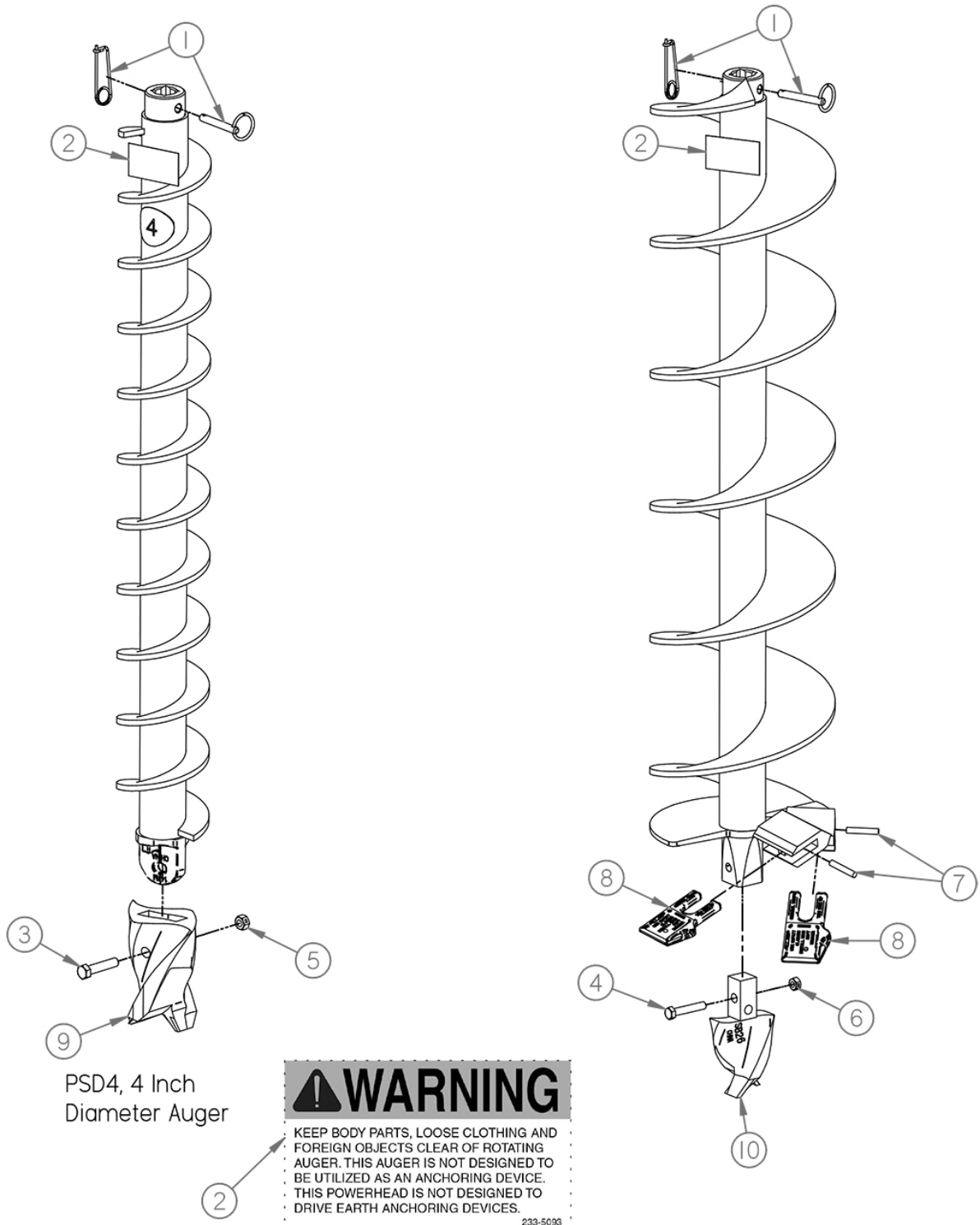

*Replacement Parts Diagram  
 PSD & PLDBH Series Augers (4 Thru 12 Inch Diameter)  
 7/8 Inch Square Drive Connection  
 For Use With 348H Hole Digger*

Reference Number	Part Number	Description	Application	Quantity
1	2021PAK3	Pak3, Pin, Auger, .312D	PSD4 Thru PLDBH12	1
2	233-5093	Decal, Caution, Clear Rotating	All Augers	1
3	15061400	HHCS, 3/8-16 X 1-3/4, ZY	PSD4	1
4	15051400	HHCS, 5/16-18 X 1-3/4, ZY	PLDBH6 Thru PLDBH12	1
5	52060000	Nut, Lock, 2-Way, 3/8-16, ZY	PSD4	1
6	52050000	Nut, Lock, 2-Way, 5/16-18, ZY	PLDBH6 Thru PLDBH12	1
7	RLPAK21	Pak21, Lock, Rubber	PLDBH6 Thru PLDBH12	As Req.
8	35HFCAK7	Pak7, Tooth, Dirt, Hardfaced, (Includes 7 Each PN: RL, Lock, Rubber)	PLDBH6 Thru PLDBH12	As Req.
9	SB45	Bit, Screw, Auger, (Includes Ref. 3 & 5)	PSD4	1
10	SB26PAK3	Pak3, Bit, Screw, Auger, (Includes Ref. 4 & 6)	PLDBH6 Thru PLDBH12	1

## Replacement Parts Diagram PSD Series Augers (14 Thru 18 Inch Diameter) 7/8 Inch Square Drive Connection For Use With 348H Hole Digger

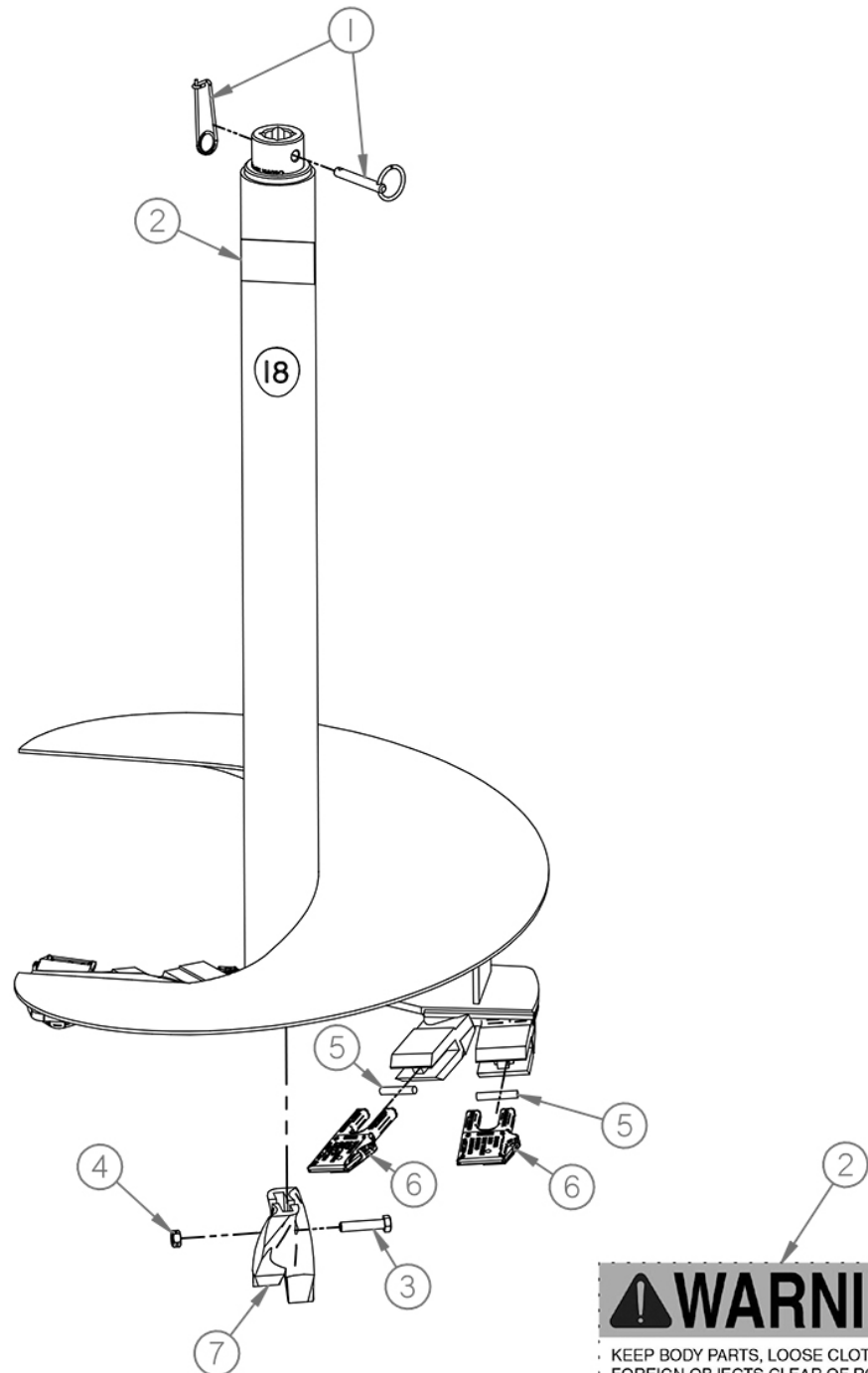

**⚠ WARNING**  
KEEP BODY PARTS, LOOSE CLOTHING AND FOREIGN OBJECTS CLEAR OF ROTATING AUGER. THIS AUGER IS NOT DESIGNED TO BE UTILIZED AS AN ANCHORING DEVICE. THIS POWERHEAD IS NOT DESIGNED TO DRIVE EARTH ANCHORING DEVICES.

233-5093

*Replacement Parts Diagram  
 PSD Series Augers (14 Thru 18 Diameter)  
 7/8 Inch Square Drive Connection  
 For Use With 348H Hole Digger*

Reference Number	Part Number	Description	Application	Quantity
1	2021PAK3	Pak3, Pin, Auger, .312D	PSD14 Thru PSD18P	1
2	233-5093	Decal, Caution, Clear Rotating	All Augers	1
3	15051200	HHCS, 5/16-18 X 1-1/2, ZY	PSD14 Thru PSD18P	1
4	52050000	Nut, Lock, 2-Way, 5/16-18, ZY	PSD14 thru PSD18P	1
5	RLPAK21	Pak21, Lock, Rubber	PSD14 Thru PSD18P	As Req.
6	35HFCPAK7	Pak7, Tooth, Dirt, Hardfaced, (Includes 7 Each PN: RL, Lock, Rubber)	PSD14 Thru PSD18P	As Req.
7	SB25PAK3	Pak3, Bit, Screw, Auger, (Includes Ref. 3 & 4)	PSD14 Thru PSD18P	1