



OPERATOR'S MANUAL

Safety, Operation & Service Information

SURFACEPRO™ Edge Grinder

Model: SG7

Form: GOM03042003US, Version 1.1, Original Instructions

- Do not discard this manual.
- Keep manual readily available for reference during operation or when servicing product.
- Before operation, read and comprehend operator manual content.
- **Customer Service:** 001 507 451 5510
- **Customer Service Telefax:** 001 507 451 5511
Note: There is no charge for Customer Service.
- **Internet Address:** <http://www.generalequip.com>
- **Email:** general@generalequip.com
- **Mailing Address:**
General Equipment Company, 620 Alexander Dr. S.W., P.O. Box 334, Owatonna, MN 55060, USA

Copyright 2021, General Equipment Company, All rights reserved.

TABLE OF CONTENTS

1 INTRODUCTION 3

2 INTENDED USE 3

3 TRAINING 3

4 SAFETY SYMBOLS..... 3

5 SAFETY INSTRUCTIONS 3

6 MACHINE SPECIFICATIONS 7

7 STANDARD PRODUCT & ACCESSORIES 7

8 MACHINE SET-UP 7

9 APPLICATION THEORY & TECHNIQUES 9

10 OPERATING INSTRUCTIONS 10

11 MAINTENANCE INSTRUCTIONS 13

12 SERVICE/REPAIR INSTRUCTIONS 14

13 TROUBLESHOOTING 14

14 STORAGE 15

15 END OF LIFECYCLE 15

16 REPLACEMENT PARTS 16

- It is responsibility of owner(s) and/or operator(s) to establish, monitor and constantly upgrade all safety programs and/or practices utilized in and for operation of Edge Grinder. Purpose of such programs is to provide for owner(s) and/or operator(s) safety. Operators must be instructed to recognize and avoid unsafe conditions associated with their work (29 CFR 1926.21 (b)(2)) and/or applicable updated revisions.
- It is responsibility of owner(s) and/or operator(s) to determine no modifications and/or alterations have been made to Edge Grinder. Modifications and/or alterations can lead to possibility of serious damage, injury or even death. It is responsibility of owner(s) and/or operator(s) to make this Operator Manual available for consultation during all phases of operation.
- Refer to OSHA 2207 and/or applicable updated revisions which contains all OSHA job safety, health rules and regulations (1926 and 1910) covering construction.

CAUTION

The concept of electrically powered, walk-behind edge grinding equipment has been successfully utilized for many years as a practical solution to many types of surface grinding requirements. The basic concept is proven and well accepted within the associated marketplaces.

Use of an Edge Grinder requires strenuous work activity. This type of work activity can be considered to be greater in magnitude than that experienced with the use of many other types of both light construction and lawn and garden related equipment. This type of work activity should only be attempted by operators of adequate physical size and stature, mental awareness, and physical strength and condition.

The body parts most noticeably affected during the surface grinding process are the arms, hands, wrists, shoulders, lower back and legs. The grinding process can also produce excessive stress/strain directly to the back muscles, spinal vertebrae and many other body parts. Back and wrist related pain can be side effects of using the Edge Grinder. Use of Edge Grinder may only aggravate this and any other medically related problem.

Because of the diverse type of prevailing surface grinding conditions, operator experience levels and operator physical characteristics, no warranty, guarantee, representation and/or liability is made by the manufacturer as to the absolute correctness or sufficiency of any operational procedure, operational position and/or technique. There is no absolute guarantee that an operator of any given experience level, physical size and/or physical condition will be immune to the possibility of and/or probable physical side effects of the normal use of the Edge Grinder.

Each potential operator of the Edge Grinder must be made aware of and assume the operational and physical liability described and/or associated with the use of the Edge Grinder. **Each potential operator not willing to assume the operational and physical liability described and/or associated with the use of the Edge Grinder should not operate it.** Proper levels of operator experience, skill and common sense are essential for maximizing the safe and efficient operation of the Edge Grinder.

Record Edge Grinder and electric motor serial numbers in spaces provided below.

Model Number: _____

Serial Number: _____

Electric Motor Serial Number: _____

Date of Purchase: _____

Specifications and design are subject to change without notice or obligation. All specifications are general in nature and are not intended for specific application purposes. General Equipment Company reserves the right to make changes in design, engineering or specifications and to add improvements or discontinue manufacture at any time without notice or obligation. General Equipment Company and its agents accept no responsibility for variations which may be evident in actual products, specifications, pictures and descriptions contained in this publication.

NOTICE TO OPERATORS

IF YOU CAN NOT READ OR DO NOT FULLY UNDERSTAND THE CONTENTS OF THIS MANUAL, PLEASE CONTACT THE FACTORY FOR PROPER ASSISTANCE BEFORE ATTEMPTING TO OPERATE THIS PRODUCT.

SI TU NO PUEDES LE'ER O NO COMPRENDES EL CONTENIDO DE ESTE MANUAL FAVOR DE PONERSE EN CONTACTO CON LA FABRICA PARA ASISTENCIA-APROPIA ANTES DE INTENTAR PARA OPERAR ESTE PRODUCTO.

SOLLTEN SIE DIESE GEBRAUCHSANWEISUNG NICHT LESEN KOENNEN ODER ES NICHT VOLLKOMMEN VERSTEHEN, WENDEN SIE SICH BITTE AN DEN HERSTELLER FUER RICHTIGE HILFE EHE SIE VERSUCHEN DIESES PRODUKT ZU OPERIEREN.

SI VOUS NE LISEZ OU NE COMPRENDRE ENTIEREMENT LES MATIERES DE CE MANUEL, S'IL VOUS PLAIT, CONTACTEZ L'USINE POUR L'ASSISTANCE APPROPRIEE AVANT D'UTILISER LE PRODUIT.

IMPORTANT:

- DO NOT allow anyone to operate Edge Grinder without first reading this Operator Manual and becoming familiar with Edge Grinder operation.
- Manufacturer of this Edge Grinder has gone to great extremes to provide owner(s) and/or operator(s) with the finest equipment available for its intended job function of grinding cement and asphalt surfaces. Yet, the possibility exists Edge Grinder can be utilized in and/or subjected to job applications not perceived and/or anticipated by manufacturer. Such misuse and/or misapplication of Edge Grinder can lead to possibility of serious damage, injury or even death.
- It is responsibility of owner(s) and/or operator(s) to determine Edge Grinder is utilized and/or operated within scope of its intended job function.

OPERATOR INSTRUCTIONAL DATA SHEET

The following undersigned operators of Edge Grinder described and/or pertaining to this Operator Manual have received formal safety and operational information/instruction from undersigned owner(s)/instructor(s) in accordance to OSHA 29 CFR 1926.21 (b)(2) and/or applicable updated revisions pertaining to, but not necessarily limited to the:

1. READING, COMPREHENSION AND ACKNOWLEDGEMENT OF MATERIAL COMPRISING ENTIRE CONTENTS OF APPLICABLE OPERATOR MANUAL FOR EDGE GRINDER.
2. FORMALIZED OPERATOR SAFETY PROGRAM TO BE DEvised BY OWNER OF EDGE GRINDER IN CONJUNCTION WITH CONTENTS OF APPLICABLE OPERATOR MANUAL FOR EDGE GRINDER.
3. OSHA RULES AND REGULATIONS RESEARCHED FOR AND/OR BY OWNER OF EDGE GRINDER AND DEEMED APPLICABLE TO SAFE AND PROPER USE AND/OR OPERATION OF EDGE GRINDER FOR ANY SPECIFIC JOB APPLICATION.
4. LOCAL LAWS, REGULATIONS AND CUSTOMS RESEARCHED FOR AND/OR BY OWNER OF EDGE GRINDER AND DEEMED APPLICABLE TO SAFE AND PROPER USE AND/OR OPERATION OF EDGE GRINDER FOR ANY SPECIFIC JOB APPLICATION.
5. FORMALIZED MAINTENANCE PROGRAM FOR EDGE GRINDER TO BE DEvised BY OWNER OF EDGE GRINDER IN ACCORDANCE WITH, BUT NOT NECESSARILY LIMITED TO, SPECIFICATIONS, GUIDELINES AND OPERATIONAL INFORMATION CONTAINED IN APPLICABLE OPERATOR MANUAL.
6. COMPREHENSIVE OPERATIONAL INSTRUCTIONS FOR CORRECT AND PROPER USE OF EDGE GRINDER AS PER CONTENTS OF APPLICABLE OPERATOR MANUAL.

_____	Operator	_____	Owner/Instructor	_____	Date
_____	Operator	_____	Owner/Instructor	_____	Date
_____	Operator	_____	Owner/Instructor	_____	Date
_____	Operator	_____	Owner/Instructor	_____	Date
_____	Operator	_____	Owner/Instructor	_____	Date
_____	Operator	_____	Owner/Instructor	_____	Date
_____	Operator	_____	Owner/Instructor	_____	Date
_____	Operator	_____	Owner/Instructor	_____	Date
_____	Operator	_____	Owner/Instructor	_____	Date
_____	Operator	_____	Owner/Instructor	_____	Date
_____	Operator	_____	Owner/Instructor	_____	Date
_____	Operator	_____	Owner/Instructor	_____	Date
_____	Operator	_____	Owner/Instructor	_____	Date
_____	Operator	_____	Owner/Instructor	_____	Date
_____	Operator	_____	Owner/Instructor	_____	Date
_____	Operator	_____	Owner/Instructor	_____	Date
_____	Operator	_____	Owner/Instructor	_____	Date
_____	Operator	_____	Owner/Instructor	_____	Date

NOTE: INSERT COPIES OF THIS PAGE WITHIN OPERATOR'S MANUAL IF SPACE FOR ADDITIONAL OPERATORS IS REQUIRED.

1 INTRODUCTION

Congratulations on your decision to purchase a General Equipment light construction product. From our humble beginnings in 1955, it has been a continuing objective of General Equipment Company to manufacture equipment that delivers uncompromising value, service life and investment return. Because of this continuous commitment for excellence, many products bearing the General name actually set the standard by which competitive products are judged.

When you purchased this product, you also gained access to a team of dedicated, knowledgeable, support personnel that stand willing and ready to provide field support assistance. Our team of sales representatives and in-house factory personnel are available to ensure each General product delivers the intended performance and product safety you expect. Our personnel can readily answer your questions or concerns regarding proper applications, service requirements and warranty related problems.

If you have any questions or concerns about this product, please feel free to contact our Customer Service Department during normal business hours using the contact information located on the front cover of this manual. There is no charge for this service.

Sincerely,
The General Equipment Team

2 INTENDED USE

The Edge Grinder is intended for use in smaller spot applications and edge grinding of cement and asphalt surfaces in a nonexplosive atmosphere. The machine is operated by one adult of proper operator experience/skill/common sense, height, weight, strength and physical condition. Minors should never be allowed to operate the Edge Grinder.

Edge Grinder is classified as a low cost, push style, low power, portable type machine. The number of practical and/or suitable job applications for this type machine is limited. Particular job application variables and operator experience/skill/common sense may require a different type machine, method and/or process to properly complete job efficiently and safely. Contact Customer Service Department for specific information regarding suitable job applications, job sites, flooring conditions and operator experience/skill/common sense recommendations for Edge Grinder BEFORE utilization.

Never exceed the recommended capacities of the Edge Grinder. Refer to BEFORE OPERATING and SPECIFICATIONS sections in this manual for more detailed information. Always utilize the correct grinding cup wheel and extension cord designed for use with the Edge Grinder. Use of an incorrect grinding cup wheel or extension cord can result in property damage and/or personal injury.

OPERATIONAL DISCLAIMER

The manufacturer of this Edge Grinder makes no warranty or guarantee it is merchantable and/or suitable for a specific job application and that it will have the capability and power required to remove any specific floor covering from any specific work surface.

3 TRAINING

Develop a comprehensive program for safe Edge Grinder operation by owner(s) and/or operator(s). Program will include, but is not limited to: instructional operation requirements, applicable OSHA requirements, local laws, and regulations, job site safety plus Edge Grinder maintenance. Constantly examine and upgrade program to guarantee owner(s) and/or operator(s) safety. Each operator must be fully instructed regarding specifics of this safety program.

4 SAFETY SYMBOLS

SAFETY ALERT SYMBOL & SIGNAL WORDS

The safety alert "general warning" symbol indicates a potential personal injury hazard. A signal word (DANGER, WARNING, or CAUTION) is used with the alert symbol to designate the degree or level of hazard seriousness. Other safety symbols may be used to represent the type of hazard in combination with "general warning" symbol, in highlighted boxes, or individually.

DANGER:

Indicates a hazard with a high level of risk which, if not voided, *will* result in death or serious injury.

WARNING:

Indicates a hazard with a medium level of risk which, if not avoided, *could* result in death or serious injury.

CAUTION:

Indicates a hazard with a low level of risk which, if not avoided, *could* result in minor or moderate injury.

The following safety alert symbols identify important safety messages in this manual. When you see these symbols, be alert to the possibility of personal injury and carefully read the message that follows.

SAFETY SYMBOLS & MEANINGS

Symbol	Meaning	Symbol	Meaning
	Action Required		No Trash Containers
	Read Manual		General Warning
	Wear Ear Protection		Warning, Flammable Material
	Wear Eye Protection		Warning, Explosive Material
	Wear Protective Gloves		Warning, Toxic Material
	Wear Safety Shoes		Warning, Electricity
	Wear Breathing Protection		Warning, Body Entrapment
	Disconnect From Power		Warning, Sharp Element
	No Open Flame		Warning, Floor Level Obstacle
	No Smoking		Warning, Drop Off
	No Active Mobile Phone		Warning, Slippery Surface
	No Food Or Drink		

5 SAFETY INSTRUCTIONS



WARNING

- These safety instructions provide guidelines to promote safety and efficiency with the Edge Grinder.
- No warranty, guarantee or representation is made by manufacturer as to absolute correctness or sufficiency of any information or statement.
- Safety instructions are intended to deal with common practices and conditions encountered in use of Edge Grinder and are not intended to be all inclusive.
- Not following instructions in this manual can result in property damage, personal injury and/or death.



DANGER



- This product can expose you to chemicals including greases, lubrication oils, silica dusts and asbestos which are known to the State of California to cause cancer and carbon monoxide (if gasoline engine powered) which can cause birth defects or other reproductive harm. For more information: www.P65Warnings.ca.gov.

BEFORE OPERATING



1. BEFORE operating Edge Grinder, read this manual to familiarize each operator with correct operating procedures.
2. Visually inspect Edge Grinder per MAINTENANCE INSTRUCTIONS STEPS 5 through 10 of this manual.
3. Determine Edge Grinder is in original, factory configuration and has not been modified in any manner. If questions arise about possible modifications, contact the Customer Service Department BEFORE utilization. There is no charge for this service.
4. Always start and stop Edge Grinder according to instructions to minimize possibility of unexpected or uncontrolled grinding cup wheel movement. Know how to stop unit in an emergency.

Physical Exertion/Body Strain

Operating Edge Grinder requires proper physical stamina, mental alertness and is strenuous. Operators must be in proper physical condition, mental health and not under the influence of any substance (drugs, alcohol, etc.) which might impair vision, dexterity or judgement. Take work breaks to maintain stamina and alertness. If you have condition(s) that might be aggravated by strenuous work, check with doctor BEFORE operating.

Vibration

Prolonged use of Edge Grinder (or other, similar machines) exposes operator to vibrations which may produce Whitefinger Disease (Raynaud's Phenomenon) reducing hand's ability to feel and regulate temperature, produce numbness, and burning sensations plus may cause nerve, circulation damage and tissue necrosis. Continuous and regular users should closely monitor condition of hands and fingers. After each period of use, exercise to restore normal blood circulation. If any symptoms appear, seek medical advice immediately.

Noise

Edge Grinder and actual surface grinding process creates exposure to high noise emission levels that can result in hearing loss or damage. Hearing protection is required while operating or when near operating equipment. Continuous and regular operators should have their hearing checked regularly.

Clothing

Clothing must be sturdy, snug fitting, but allow complete freedom of movement. Never wear loose fitting jackets, scarves, neckties, jewelry, flared or cuffed pants or anything that could become caught on controls or moving parts. Properly secure eyeglasses, hearing aid devices and other medical related devices. Wear long pants to protect legs. Protect hands and improve grip with heavy duty, nonslip gloves. Wear and properly lace sturdy boots with nonslip soles. Steel-toed safety shoes are mandatory. Wear approved safety hard hat where there is danger of head injuries and/or approved breathing mask where danger of airborne foreign particulate contamination is present.

Flying Debris

The surface grinding process can result in flying debris. Eye protection and appropriate safety apparel is required when near or operating Edge Grinder. DO NOT operate unit with onlookers or animals close by.

BACK CARE & PROPER LIFTING PROCEDURES

Operators will be required to lift the Edge Grinder as demanded by specific job applications. When lifting, one person is required. Utilize proper lifting techniques to minimize fatigue and back-related injuries.

Back Anatomy

The human body is supported by the spinal column consisting of thirty bones called vertebrae, all linked and supported by a series of muscles. Pads called discs separate each vertebrae, acting as cushions to pressure from external forces. Spinal column is wrapped by nerve system with three sections that require being kept in natural alignment to prevent discomfort:

- Cervical: From base of neck to brain.
- Thoracic: From middle to lower back.
- Lumbar: From lower back to buttocks area.

Back Care Preventative Measures

Most occupational physicians agree on several "universal" preventative measures an operator should follow to help lower risk of back-related injuries:

1. Maintain proper body weight.
2. Eliminate/reduce use of tobacco. Smoking reduces oxygen supply and nutrients to discs cushioning vertebrae.
3. Develop a consistent exercise routine.
4. Maintain good posture while walking or sitting.
5. Watch how you twist/bend your body. Twisting/bending incorrectly can exert too much pressure on discs and vertebrae.
6. Use firm footing, keep intended path clear before carrying Edge Grinder.
7. Always use proper lifting techniques as described below.

PROPER LIFTING PROCEDURES

The following are guidelines for properly lifting the Edge Grinder are not intended to be all inclusive. Plan your path and make sure there are no obstructions or tripping hazards. Consider how you will set the load. The spinal column is a very sensitive mechanism. At any given time, improper lifting procedures can cause damage that can lead to injury.

1. Position feet a comfortable distance (shoulder width) apart to help provide necessary balance.
2. Tighten stomach muscles by pulling in your stomach. Keep back as straight as possible to keep spine, back muscles/ligaments in alignment.
3. Bend at hips and knees as much as possible.
4. Start lifting Edge Grinder by thrusting feet while lifting as much as possible with leg muscles. Use smooth movements.
5. Once Edge Grinder is lifted, keep it close as possible to the body. Avoid turning at waist. To turn, pivot entire body.
6. Keep shoulders, hips and feet pointed in same direction.

IMPORTANT: Use firm footing, keep intended path clear before carrying Edge Grinder.

TRANSPORTATION



1. When transporting Edge Grinder, remove extension cord and store, store machine power cord on cord retention device on side of operator handle:
 - a) To and from jobsite.
 - b) Longer distances while being repositioned on jobsite.
 - c) Traversing up and down stairways.
 - d) Performing maintenance and/or repairs.
 - e) Lifting/lowering from transportation vehicle.

WARNING

- Disconnect extension cord from Edge Grinder when traversing up and down stairs.
- Store Edge Grinder power cord on operator handle retention device when traversing up and down stairs.
- Improperly stored/connected cords can entrap and/or entangle personnel.
- Such occurrence can result in property damage and/or personal injury.

2. To lift and carry the Edge Grinder grab operator handle shaft, using one hand, just above where handle attaches to main frame portion of unit. FIGURE 1



FIGURE 1

3. As unit is lifted, using proper lifting procedures, use other hand to place down-pressure on opposite end of operator handle. This will balance unit on first hand in STEP 2. Operator handle will be fairly level to ground with front edge of dust collection shroud pointing upward. FIGURE 2



FIGURE 2

4. To reduce storage area and minimize damage, transport Edge Grinder in normal upright position with operator handle assembly removed from main frame. Refer to STEP 7 of INSTALLING & REMOVING OPERATOR HANDLE of MACHINE SET-UP section in this manual to remove handle assembly.
- DO NOT allow operator handle and main frame to make direct contact with each other while transporting. Provide proper protection between Edge Grinder components and vehicle.
 - DO NOT drop unit directly against grinding cup wheel area. Provide support block under main frame to prevent direct contact and/or damage to grinder cup wheel and related components.

DANGER

- DO NOT attempt carrying/lifting/lowering Edge Grinder and/or doing so into/from transportation vehicle if person is not in proper physical/mental condition or unfamiliar in proper lifting procedures.
- Such actions can result in property damage and/or personal injury.

5. All equipment must be secured in/on vehicles with suitable strapping or tie downs. Personnel should not be transported in same compartment as equipment and supplies. Consult applicable OSHA regulations for specific information.

CAUTION

- An improperly secured Edge Grinder and related accessories can fall from moving vehicle and result in property damage and/or personal injury.

DETERMINATION OF POTENTIAL SUBSURFACE HAZARDS IN PROPOSED SURFACE GRINDING LOCATION(S)



Edge Grinder operator handle grips are constructed of non-metallic composite material and do not guarantee operators will be properly insulated from contact with charged electrical cables. Edge Grinder and related accessories are not classified as insulated.

Edge Grinder is not sealed or insulated. DO NOT operate Edge Grinder in an explosive atmosphere or near combustible materials. Refer to OSHA rules and regulations.

DANGER

- Always assume surface grinding location contains buried underground obstructions.
- BEFORE attempting to operate Edge Grinder in proposed location(s), call 811 and/or visit www.Call811.com.
- Contact all appropriate agencies to determine exact location(s) of all buried pipelines, powerlines and material debris.
- Many utilities and other agencies will perform these tasks at minimal charge or at no cost. Have all subsurface hazards marked for easy recognition.
- Direct contact with these and other subsurface hazards can result in property damage and/or personal injury through such things as electrocution and/or explosion.

WARNING

BEFORE attempting to operate Edge Grinder, identify/mark all potential subsurface hazards in proposed surface grinding location(s). Potential subsurface hazards may include, but may not be limited to the following:

1. Buried debris, rotted timbers or wood planking.
2. Buried pressurized pipelines (e.g. natural gas, propane, etc.)
3. Buried electrical cables.

DETERMINATION OF POTENTIAL ABOVE SURFACE HAZARDS IN PROPOSED SURFACE GRINDING LOCATION(S)



Normal Edge Grinder use is on level surfaces. Avoid other surface conditions which can be dangerous. Special care must be exercised on slippery, and/or difficult/uneven surfaces. Watch for cracks, high spots/other surface irregularities or drop offs to lower floor levels. Operate only when/where visibility and light are adequate for job at hand. Remove any trip/fall hazard BEFORE operating Edge Grinder. Keep proper footing and balance at all times.

WARNING

- DO NOT operate Edge Grinder on jobsite location where forces generated during surface grinding process can allow body parts to come in direct contact with vertical wall, foundation or other support type structures in close proximity.
- Such occurrence can result in property damage and/or personal injury. Always maintain a safe and reasonable distance from these type structures.

OPERATIONAL HAZARDS



- Edge Grinder is designed to substantially enhance machine control and reduce operator fatigue provided grinding cup wheel does not directly contact larger, protruding obstructions (anchor bolts, pipes, nail heads, columns, openings, large cracks, utility outlets, material variances, etc., or any objects protruding from work surface). Such contact can result in rapid and jerky movement of machine and/or loss of machine control.

CAUTION

- Exercise extreme caution when operating Edge Grinder in vicinity of anchor bolts, pipes, columns, openings, large cracks, utility outlets or any object protruding from work surface.
- Contact with such objects can lead to loss of machine control, resulting in property damage and/or personal injury.

WARNING

- Exercise extreme caution when operating Edge Grinder on above ground level floors to prevent loss of control allowing machine and/or operator to fall down to lower levels.
- When moving backwards during surface grinding process, be aware of potential drop-offs and obstructions on job site.

- The surface grinding process can produce sparks, dusts and other foreign particle contamination that can result in fire and/or explosion depending on existing jobsite conditions.

WARNING

- Sparks produced by action of grinding cup wheel against work surface (e.g.- striking anchor bolts) can result in fire and/or explosion depending on existing environmental conditions.
- This occurrence can result in property damage and/or personal injury.

- Many coating materials, adhesives or mastics can contain asbestos and other chemicals that are known to cause physical harm and/or affect the environment.
- Excessive water, and/or other conductive materials on work surface can result in electrocution of operator and/or other personnel.

WARNING

- Water and other conductive materials on work surface increases electrocution hazard potential for operator and other personnel.
- Determine Edge Grinder is properly grounded (no faults), power cords are free of cuts, abrasions and/or exposed cable strands.
- Improper grounding and use of damaged power cords and/or GFI can result in property damage and/or personal injury.
- DO NOT expose Edge Grinder to rain or wet operating conditions.
- Water entering machine can increase risk of electric shock.

Preventive Measures:

- Operator must maintain physical and mental alertness. Be prepared for unexpected grinding cup contact with protruding anchor bolts, etc. and be capable to sense level of machine control they have.
- DO NOT operate Edge Grinder on jobsite where kickback forces can allow body parts to come in direct contact with vertical wall, foundation or other support type structures. Maintain a safe and reasonable distance from these structures.

- Maintain proper operating stance for better control of machine plus, reducing operator error and fatigue. Refer to PROPER OPERATOR STANCE in OPERATING INSTRUCTIONS section of this manual for more information.
- Remove water and/or conductive materials by industry-approved and/or accepted practice BEFORE grinding surface. Determine Edge Grinder is properly grounded and extension cords are free of cuts, abrasions and/or exposed cable strands.
- Dust and other particle contamination can be controlled by use of appropriate industrial-type dust collection system to remove/control dust and other particle contamination from work surface.

WARNING

- Creation of dust and other foreign particle contamination from surface grinding process can result in property damage and/or personal injury.
- For such operating conditions, always wear NIOSH/MSHA approved dust/mist respirator and appropriate safety related apparel.
- Consult applicable OSHA regulations for specific information.

WARNING

- Always use dust collection system that meets specific job site requirements.
- Dust materials can meet Class II and Class III National Electric Code specifications for hazardous materials.
- Consideration must be given to creation of hazardous materials requiring specific disposal procedures.
- Determine dust collection system is properly designed to operate within these atmospheres.
- Consult current National Electric Code, OSHA and EPA regulations for specific information.

WARNING

- Always utilize water mist spray system to operate within specific job site requirement.
- Dust materials can meet Class II or Class III National Electric Code specifications for hazardous materials.
- Consideration must be given to creation of hazardous materials requiring specific disposal procedures.
- Determine water mist spray system is properly designed to operate within these atmospheres.
- Consult current National Electric Code, OSHA and EPA regulations for specific information.

6 MACHINE SPECIFICATIONS

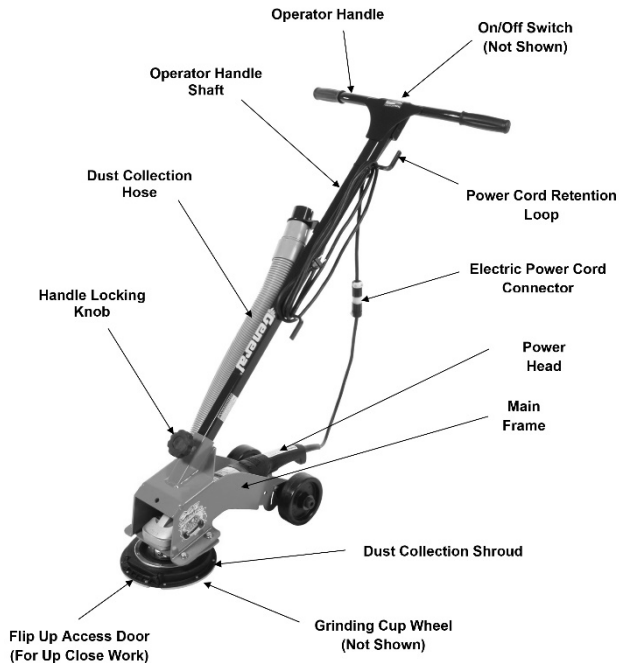

FIGURE 3

FRAME STRUCTURE	Unitized, welded steel plate.
DRIVE SYSTEM	Direct shaft mount.
ARBOR SHAFT THREAD	5/8-UNC 11 right hand thread
NOMINAL GRINDING CUP WHEEL SPEED	3400 RPM
MAIN FRAME WIDTH	9-1/2 inches (241.3 mm) at dust shroud
MAIN FRAME LENGTH	20-1/16 inches (509.5 mm)
OPERATOR HANDLE WIDTH	23-3/64 inches (585.4 mm)
OPERATING LENGTH	37-5/16 inches (947.7 mm)
OPERATING HEIGHT	36-63/64 inches (936.2 mm)
WEIGHT	39 lbs (17.7 Kg), less grinding cup wheel
ELECTRIC MOTOR	2300W, 115 VAC, 60 HZ, 15 Amperes thermally protected.
EXTENSION CORDS	Minimum rating for non-manufacturer supplied extension cords SJTW 12 AWG/3C (3 x 3.31 mm ²) up to a maximum cord length of 75 feet (22.9 M).
OPERATING ENVIRONMENTS	Non-hazardous type locations.
REQUIRED NUMBER OF OPERATORS	1

NOISE & VIBRATION EMISSIONS

Description	North America	Europe
Model	SG7	
Noise Level	94 db	
Vibration Level	6.2 m/s ²	

EDGE GRINDER POWER SOURCE

The Edge Grinder is designed to operate from a clean, 15 ampere, 115 VAC, 60 Hz, nominal power source. Contact Customer Service Department for information for operation from 220 VAC, 50 Hz power source. Clean power refers to amperage available from individual electrical circuit selected.

Additional electrical products already using same circuit will reduce available amperage resulting in starting/operational difficulties. Check proper voltage and amperage levels in addition to power source being properly grounded.

Proper voltage and amperage to electric motor is essential for maximum productivity and service life. Low voltage and amperage will cause motor to overheat and can cause unrepairable damage to motor and related controls. An improperly grounded circuit increases risk of electric shock. A qualified electrician may need to be consulted.

IMPORTANT: Operating Edge Grinder with improper voltage and/or amperage will result in unrepairable damage to electric motor and related controls.

7 STANDARD PRODUCT & ACCESSORIES

Refer to FIGURE 3 for overview description of standard components included in machine. Included in shipment for SG7 SurfacePro Edge Grinder should be the following:

- 1 each, Model SG7 SurfacePro Edge Grinder main frame assembly
- 1 each, Operator handle assembly
- 1 each, 2 inch diameter dust collection hose with couplers, part # SG7-0090
- 1 each, 7 inch diameter grinding cup wheel, part # SG7-2000-30
- 1 each, Final inspection form

ACCESSORIES

NOTE: Cup grinding wheel is for use in general purpose projects on both cement and asphalt surfaces unless otherwise designated.

	Part #	Description	Weight (in lbs)
	SG7-2000-30	Wheel, diamond, 7 inch diameter, 30 grit	1.4

8 MACHINE SET-UP



Open the shipping carton immediately upon receipt. Remove Edge Grinder from cartons. Visually inspect contents for freight damage and/or missing parts. If shipping damage is evident, contact delivering carrier immediately to arrange for an inspection of damage by their claims representative. **DO NOT DESTROY OR DISCARD SHIPPING CARTON UNTIL INSTRUCTED BY AUTHORIZED REPRESENTATIVE OF CARRIER OR FACTORY.** If missing parts are detected, notify your dealer who will assist you in obtaining them.

NOTE: If ordered with Edge Grinder, additional accessories can be shipped separately or included in shipping carton.

NOTE: Edge Grinder is shipped from factory with operator handle assembly uninstalled to main frame. All lubrication fittings are lubricated at factory and will not require further servicing until first scheduled maintenance.

INSTALLING & REMOVING OPERATOR HANDLE

Installation of operator handle will require a level work surface of appropriate size and height.

Tools Required:
No tools required.

1. Set main frame assembly on work surface making sure all wheels and grinding cup wheel/dust shield area are in contact with surface.
2. Loosen operator handle locking knob until threaded stud end is flush with inside of operator handle receiver. **DO NOT** remove completely. FIGURE 4.



FIGURE 4

- Slide bottom end of operator handle assembly into operator handle receiver of main frame until fully seated. FIGURE 5



FIGURE 5

IMPORTANT: Small round hole near end of operator handle must be facing up to allow locking knob to pass completely through and secure operator handle.

WARNING

- Operator handle assembly must be fully engaged and secured in position to main frame.
- Improper assembly to main frame can result in property damage and/or personal injury.

- Hand tighten operator handle locking knob to fully secure operator handle shaft assembly to main frame. Approximately 3/8 inch only of locking knob thread will be exposed above operator handle receiver when secured.
- Determine Edge Grinder ON/OFF switch is in OFF position and unit is not connected to power source.

WARNING

- Unexpected machine start-up can result in property damage and/or personal injury.

- Attach free end of dust collection hose to hose attachment bracket on side of operator handle until fully seated. FIGURE 6



FIGURE 6

- Connect power head power cord to power cord located at switch end of operator handle assembly. Twist to lock to prevent separation. FIGURE 7



FIGURE 7

- To remove operator handle assembly, turn ON/OFF switch to OFF position and disconnect unit from power source (if applicable). Disconnect power cords by reversing STEP 7, disconnect dust collection hose by reversing STEP 6, loosen operator handle locking knob by reversing STEP 4, then remove operator handle from main frame operator handle receiver. FIGURE 8



FIGURE 8

- Inspect all fasteners for looseness. Tighten as necessary. Consult fastener torque chart for proper torque value if any fastener requires retorquing.
- Determine all components of Edge Grinder allow for proper function as stated in this operator manual.

WARNING

- Determine all components of Edge Grinder allow for proper function and meet minimum operational standards as stated in this operator manual.
- Improper functioning components can result in property damage and/or personal injury.

INSTALLING & REMOVING ACCESSORY GRINDING CUP WHEEL



Tools Required:
No tools required.

Parts Required:
1 each, grinding cup wheel appropriate for job application with 5/8-11 UNC right hand thread.

DANGER

- Wear appropriate safety glasses and other appropriate safety apparel when installing or removing grinding cup wheel on Edge Grinder.
- Improper contact with sharp edge can result in property damage and/or personal injury.

1. Turn Edge Grinder ON/OFF power switch to OFF position. Disconnect extension cord from power source. Disconnect extension cord from Edge Grinder power cord.

WARNING

- Unexpected machine start-up can result in property damage and/or personal injury.

2. Tilt Edge Grinder back until operator handles contact floor. Apply appropriate weight to handle and chock wheels to stabilize to prevent unexpected movement and/or falling of machine. Other methods can be used to appropriately support/stabilize machine. FIGURE 9



FIGURE 9

WARNING

- Exercise extreme caution when working near or under Edge Grinder in servicing position.
- If Edge Grinder is not positioned on stable work surface or in stable configuration unexpected movement can allow Edge Grinder to fall forward relative to work surface.
- This occurrence can result in property damage and/or personal injury.

3. Facing bottom side of machine main frame and segment side of grinding cup wheel, use one hand to depress black transmission lock button near side, front portion of power head to prevent arbor shaft rotation, FIGURE 10. Grinding cup wheel may require slight movement back and forth for transmission lock to fully engage.



FIGURE 10

4. While keeping transmission lock button depressed, use other hand to rotate grinding cup wheel in counterclockwise direction to remove it from arbor shaft. Once removed store properly. If installing new grinding cup wheel proceed to STEP 5. If no grinding cup wheel is to be reinstalled, proceed to STEP 7 below.

CAUTION

- New and existing grinding cup wheels can have sharp edges.
- Proper handling must be taken when removing from package, installing/removing from machine, or transporting machine.
- Improper handling can result in property damage and/or personal injury.

5. To install new grinding cup wheel, depress transmission lock button to prevent arbor rotation. Arbor shaft may require slight movement back and forth for transmission lock to fully engage. FIGURE 11



FIGURE 11

6. Thread new grinding cup wheel onto arbor shaft by rotating in clockwise direction until grinding cup wheel is fully seated. Hand tighten only. FIGURE 11

CAUTION

- DO NOT use any tool for tightening/loosening grinding cup wheel.
- DO NOT apply any impact force to grinding cup wheel.
- Using any tool and/or applying excessive impact force or torque can result in property damage and/or personal injury.

7. If Edge Grinder is to be placed back into service immediately, lower machine so grinding cup wheel rests on floor then reverse procedure in Step 1 under INSTALLING & REMOVING ACCESSORY GRINDING CUP WHEEL. If not being placed back into immediate service, refer to STORAGE INSTRUCTIONS section of this manual.

9 APPLICATION THEORY & TECHNIQUES



The Edge Grinder operates on the principle of accessory 7 inch diameter grinding cup wheels with 5/8-UNC 11 thread attached to a power head with circular action to remove/level a variety of imperfections, adhesives, mastics and coatings from cement and asphalt work surfaces. Accessory grinding cup wheels used will affect type of materials to be removed, material removal rate(s) and resulting smoothness of work surface.

Grinding process is directly controlled by:

1. Grinding cup wheel type: number of grinding segments plus segment grit level and bond matrix.
2. Sufficient machine weight and/or down force as provided by operator to grinding cup wheel to effectively penetrate and remove work surface type coatings and base material itself.
3. Adequate force exerted against Edge Grinder by operator to move grinding cup wheel across work surface to deliver acceptable productivity rates.
4. Type, density, thickness and adhesion of adhesives, mastics, thinsets and age, condition, tensile strength of the concrete or asphalt.

5. No two work surfaces or applied type coating materials onto work surface are exactly alike, no two work surfaces or applied type coatings materials can be removed by exact same method and overall operator feed rates. The grinding process, along with operator experience, skill and common sense, suggests work surface grinding is a matter of trial and error and directly determines overall success of the job application.

ACCESSORY GRINDING CUP WHEEL & APPLICATIONS

Grinding cup wheels that can be used with the Edge Grinder come in a wide variety of configurations based on number and style of segments plus grit and bond matrix formulations too numerous to mention in this manual. The Edge Grinder factory supplied grinding cup wheel is made from high quality steel and diamond matrix segments selected to cover a wide variety of applications while delivering optimal performance and productivity on cement or asphalt surfaces. FIGURE 12



FIGURE 12

Individual accessory grinding cup wheel design will vary, but basic operational characteristics are identical: circular motion against work surface and remove coatings materials and/or base material.

WORK SURFACE MATERIALS REMOVAL TECHNIQUES

The combination of factors makes it impossible to develop standardized Edge Grinder removal techniques and will require trial and error until satisfactory results are achieved. Experience gained over time, along with common sense, will help minimize the amount of necessary testing.

1. Specific type and/or density of adhesives, mastics and thinset materials that bond floor coverings to work surface and jobsite conditions can affect removal rates. Many factors directly affect operating parameters and/or techniques utilized for special job applications.
 - a) Many adhesives/mastics remain flexible in fully cured state and are usually darker or black in color.
 - b) Adhesives/mastics that become dried and non-flexible when fully cured are usually yellowish/opaque in color and require less effort to remove than darker types.
2. Adhesive/mastic densities or thicknesses vary due to work surface application rates directly affecting bond strength. Due to these variations, the type grinding cup wheel used may need to be changed to optimize removal rates. As a general rule the following is true:
3. In general, for thinner adhesives (i.e.-amount used), lower shear force is required to remove and increases removal rates. In this instance, a cup wheel with a greater number of segments and finer grit may be adequate.
4. In general, for thicker adhesives (i.e.-amount used), higher shear force is required to remove and decreases removal rates. In this instance, a cup wheel with fewer segments and a higher grit may be adequate.
5. As the number of grinding cup wheel segments is increased and/or grit becomes finer, the amount of material removed is less aggressive and productivity can be reduced depending on work surface conditions and desired result.
6. As number of grinding cup wheel segments are decreased and/or grit becomes coarser, the amount of material removed is more aggressive and productivity can be increased depending on work surface conditions and desired result.

10 OPERATING INSTRUCTIONS



IMPORTANT: DO NOT operate Edge Grinder until each operator completely comprehends contents of this manual.



CAUTION

- If Edge Grinder and/or an individual component/accessory does not appear to function properly, STOP and DO NOT operate Edge Grinder until corrective action has been completed.
- Operation with improperly functioning machine, components/accessories can result in property damage and/or personal injury.
- If you have any questions regarding proper operation of Edge Grinder, contact Customer Service Department for assistance BEFORE using. There is no charge for this service.



WARNING

- Work surface grinding process can produce excessive noise, vibration and flying debris.
- All operators and work personnel in Edge Grinder vicinity must wear appropriate safety eye wear and hearing protection.
- Other safety apparel and/or procedures, deemed necessary by supervisory personnel, must also be worn and/or practiced by all appropriate personnel.



CAUTION

- Individual operator experience, skill, common sense, job site location and specific job application will affect final decision on specific operating procedures for Edge Grinder.
- Each operator must decide if he possesses adequate/proper experience, skill and common sense for operating Edge Grinder in any given and/or specific job application.

EDGE GRINDER SET-UP ON JOBSITE

1. Position Edge Grinder on a suitable work surface.
2. Determine Edge Grinder ON/OFF switch is in OFF position and unit is not connected to power source. FIGURE 13



FIGURE 13



WARNING

- Unexpected machine start-up can result in property damage and/or personal injury.

3. Install operator handle assembly to main frame per STEPS 1 through 7 in INSTALLING & REMOVING OPERATOR HANDLE section within MACHINE SET-UP section of this manual.

4. Install accessory grinding cup wheel per procedures in INSTALLING & REMOVING ACCESSORY GRINDING CUP WHEEL in MACHINE SET-UP section of this manual (if applicable).
5. Attach dust collection hose from primary dust collection unit to top side of hose attachment bracket on side of operator handle until fully seated.
6. Lock power head ON/OFF switch into ON position by placing index finger on bottom side, front portion, of switch then rock up and toward bottom of operator handle until it locks in place. FIGURE 14



FIGURE 14

NOTE: To release power head switch to OFF position, simply press upward on back portion of switch and release. Front portion of switch will unlock and become fully exposed.

7. Connect extension cord to main power cord of Edge Grinder. FIGURE 15



FIGURE 15



WARNING

- **DO NOT** modify or replace any extension cord component without utilizing a factory approved component only.

8. Connect additional extension cord to remaining end of first extension cord (if applicable).

IMPORTANT: If additional extension cords are required, each cord must be of proper structural integrity and size (AWG) to meet applicable National Electric Code and OSHA requirements. An additional extension cord with integral GFI can be used in conjunction with Edge Grinder which also has an integral GFI.



WARNING

- **If operating Edge Grinder in outside environment, use only extension cords marked "W-A" or "W".**
- **Such cords are rated for outside usage and reduce risk of electric shock.**



WARNING

- **All electrical wiring including extension cord gauge and/or length must be installed and/or approved in accordance with local electrical codes and practices.**
- **An improper wiring installation can result in property damage and/or personal injury.**



WARNING

- **For maximum protection against a fault, if used, always configure GFI to be plugged into power source receptacle.**
- **Configurations with GFI placed between Edge Grinder and power source will not provide maximum protection against potential fault.**



WARNING

- **BEFORE** use, inspect each extension cord and wiring device for proper structural integrity.
- **DO NOT** use cord with worn or cut outer jacket material or repaired with electrical tape.
- **Use of cords with improper structural integrity can result in property damage and/or personal injury.**



DANGER

- **DO NOT** operate Edge Grinder without extension cords/GFI in proper operating condition. The GFI is intended as a safety device in event power source has a fault.
- **Always** assume electrical wiring on every jobsite can contain a fault.
- **A fault can generate a dangerous operating configuration that can result in property damage and/or personal injury.**



WARNING

- **Keep** power and extension cords free and clear of machine and blade.
- **In event** extension cord becomes entangled about Edge Grinder and/or operator turn machine OFF immediately.
- **Determine** extension cords/GFI are in proper condition to continue operation.
- **In event of damage, replace with factory approved component only and/or products meeting applicable National Electric Code and OSHA requirements.**



WARNING

- **DO NOT** abuse the power cord. **Never** use power cord to move Edge Grinder or pull plug from receptacle. **Damage to cord can result.**
- **Keep** cord away from heat, oil, sharp edges (including accessory tool) or moving parts.
- **A damaged cord increases the risk of an electric shock.**

9. Position machine on work surface with grinding cup wheel/power head facing away from operator.

PROPER OPERATOR STANCE (FIGURE 16):

10. Grasp handle grips firmly. Always hold operator handle firmly with both hands. Wrap fingers and thumbs around handle grips. Wear gloves to improve grip.
11. Attempt to keep wrists and forearms inline to operator handle shaft as much as feasible. Proper wrist position during removal process can minimize and/or reduce stress and strain related damage potential to this body area, plus, operator control can be enhanced and fatigue reduced.
12. Keep upper body as vertical as possible.

13. Keep feet comfortable distance apart for stability – shoulder width, one foot in front of the other.
14. Operator must always stand behind machine when in use.



FIGURE 16

NOTE: Using improper operator stance (FIGURE 17):

- a) Reduces operator control and balance.
- b) Increases operator fatigue.
- c) Increases risk of property damage and/or personal injury.



FIGURE 17

NOTE: Proper and improper operator stances depicted in this operator manual are not all inclusive.

STARTING EDGE GRINDER

15. Connect primary dust collection unit to power source and turn ON/OFF switch to ON position.
16. Grasp handle grip firmly in one hand and apply down force on handle to reduce load on grinding cup wheel while still in contact with work surface. Turn Edge Grinder ON/OFF switch to ON position with other hand. Grinding cup wheel begins movement when motor starts. Once motor achieves operating speed remove down force on handle. FIGURE 18



FIGURE 18



DANGER

- **DO NOT modify, bypass or disable Edge Grinder ON/OFF switch on operator handle or power head.**
- **DO NOT operate machine if machine ON/OFF switch on operator handle or power head are not functioning properly.**
- **Such configuration will not allow operator to quickly stop Edge Grinder in event of an emergency, prevent unexpected machine start-up, loss of control and/or “runaway” machine and can result in property damage and/or personal injury.**

17. Using proper operator stance, push forward with both hands on operator handle to begin work surface grinding process. If power/extension cord becomes entangled about Edge Grinding and/or operator turn machine operator handle ON/OFF switch to OFF position immediately.



DANGER

- **Always maintain proper control of Edge Grinder.**
- **Grinding cup wheel begins movement when motor starts. There is no automatic motor shut off feature on machine.**
- **If operator loses control, a “runaway” machine can result in property damage and/or personal injury.**

18. For work requiring material removal or leveling in close proximity to walls posts and similar vertical surfaces, flip dust collection shroud front access cover up and back to expose grinding cup wheel edge. Upper lip and vertical edges of access opening prevent contact with vertical surfaces unless vertical surface is lower than upper guard lip and is narrower in width than dust shroud access opening. DO NOT use front access cover feature if vertical surface configuration allows direct contact with edge of grinding cup wheel. Operate Edge Grinder with extreme care in these situations to prevent of loss of machine control. Keep Edge Grinder perpendicular to vertical surfaces as much as possible in these situations. FIGURE 19



FIGURE 19



DANGER

- **Use extreme care when operating Edge Grinder near vertical type surfaces with dust shroud front access cover in up position.**
- **Always maintain proper control of Edge Grinder.**
- **Keep Edge Grinder in perpendicular orientation to vertical surfaces in close proximity to work performed.**
- **DO NOT use front access cover if vertical surface configuration allows direct contact with grinding cup wheel.**
- **There is no automatic motor shut off feature on machine.**
- **If operator loses control, a “runaway” machine can result in property damage and/or personal injury.**

19. Consistently remove loose work surface material to determine proper material removal depths and extent of work completed. Lack of proper dust collection system and/or broom use can increase problem.

IMPORTANT: Properly dispose of all accumulated work surface materials according to international and local environmental regulations. Edge Grinder normal use creates material build-up on machine. It is highly recommended all exposed internal/external surfaces be properly cleaned after each use plus, adjust wheel scraper clearance to minimize build-up on wheels. Refer to MAINTENANCE INSTRUCTIONS section of this manual for more information.

WARNING

- Properly dispose of all accumulated work surface materials per OSHA and EPA codes/regulations.
- Many materials can be classified as hazardous requiring proper disposal procedures.
- Contact applicable government agencies for specific information.

STOPPING EDGE GRINDER



20. Turn Edge Grinder ON/OFF switch on operator handle to OFF position between each use or when moving from one major section of work surface to another. FIGURE 20



FIGURE 20

21. Turn power head ON/OFF switch to OFF position. FIGURE 21



FIGURE 21

22. Disconnect extension cord from power source. Never leave Edge Grinder connected to power source and unattended.
23. Disconnect extension cord from Edge Grinder power cord.
24. Turn ON/OFF switch of primary dust collection unit to OFF position and disconnect unit from power source. Never leave dust collection unit connected to power source and unattended.

WARNING

- Stop Edge Grinder and dust collection unit when moving from one major section of work surface to another.
- DO NOT choose to save time (time required to restart machine(s)), money (if Edge Grinder and dust collection unit is being rented) or gain added convenience by electing to keep machine(s) running between major sections.
- Never leave Edge Grinder and dust collection unit running and unattended.
- Not doing so can result in property damage and/or

11 MAINTENANCE INSTRUCTIONS



For routine maintenance, the following information should be followed at minimum once per week or 40 hours of use for maximum performance and return on investment unless otherwise indicated. Information is for reference only and is not intended to be all inclusive.

1. Use factory approved replacement parts/accessories only for maintenance and repair purposes.

WARNING

- Operating Edge Grinder utilizing components not meeting minimum operational standards can result in property damage and/or personal injury.

2. All maintenance/repairs not described in this operator manual must be done by a dedicated service center following a specific service/repair manual.
3. STOP Edge Grinder BEFORE performing maintenance per STOPPING EDGE GRINDER in OPERATING INSTRUCTIONS section of this manual.

WARNING

- Disconnect Edge Grinder extension cord from power source before performing any service work or repair.
- Failure to properly disconnect Edge Grinder power source can result in property damage and/or personal injury.

4. Remove accessory grinding cup wheel per INSTALLING & REMOVING ACCESSORY GRINDING CUP WHEEL in MACHINE SET-UP section of this manual.
5. Inspect for loose or broken parts. Inspect each grinding cup wheel for wear, sharpness and cracking. Inspect all fasteners, dust collection hose and couplers, individual parts, operator controls and safety devices for proper function. Tighten fasteners as necessary. Replace any worn or damaged part or assembly.
6. Remove all loose material accumulations, dirt and grease on internal/external surfaces and dust collection hose to prevent safety hazards, poor performance and reduced service life. Use proper dust collection system as necessary to remove most accumulation then use safety type solvent for final Edge Grinder cleaning. Failure to clean Edge Grinder can result in formation of dried material build-up reducing bearing service life and increase vibration levels felt by operator during operation.

IMPORTANT: Electric motor is an enclosed, fan cooled design. Keep power head housing air vents clear of material accumulations for proper air flow/cooling.

IMPORTANT: DO NOT use thinner, benzene, or other volatile solvents that can attack rubber/plastic components when cleaning Edge Grinder.

DANGER

- Use safety type solvent.
- Provide adequate ventilation.
- DO NOT smoke while using cleaning solvents.
- DO NOT use solvents with motor running or if it is hot.
- Allow ample time for motor to cool BEFORE using solvents.
- An ignition source in close proximity to hot motor can be source of an explosion, resulting in property damage and/or personal injury.

WARNING

- Properly dispose of all accumulated work surface materials per OSHA and EPA codes/regulations.
- Many materials can be classified as hazardous requiring proper disposal procedures.
- Contact applicable government agencies for specific information.

7. Inspect Edge Grinder operator handle and power head ON/OFF switches for proper function. If damaged or worn, replace.
8. Inspect operator handle grip surfaces for moisture, pitch, oil or grease and are not cracked, damaged or worn. If full of dirt or pitch, clean. If loose, damaged and/or worn or are missing, replace.
9. Inspect operator handle for structural integrity, cracks or abrasions.
10. Inspect all safety and operation decals for proper condition. If any decal becomes damaged and/or unreadable, replace.

12 SERVICE/REPAIR INSTRUCTIONS



The following information is intended for specific service/repair situations for the Edge Grinder. Information is for reference only and is not intended to be all inclusive.

1. Use factory approved replacement parts/accessories only for servicing/repair purposes.

WARNING

- Operating Edge Grinder utilizing components not meeting minimum operational standards can result in property damage and/or personal injury.

2. All service/repairs not described in this manual must be done by a dedicated service center following a specific service/repair manual. DO NOT service/repair Edge Grinder unless designated service/repair technician has received adequate, professional instruction regarding proper procedures.
3. STOP Edge Grinder BEFORE performing service and repair per STOPPING EDGE GRINDER in OPERATING INSTRUCTIONS section of Operator's Manual.

WARNING

- Disconnect Edge Grinder power cord from power source before performing any service work or repair.
- Failure to properly disconnect Edge Grinder power source can result in property damage and/or personal injury.

4. Remove accessory grinding cup wheel per INSTALLING & REMOVING ACCESSORY GRINDING CUP WHEEL in MACHINE SET-UP section of Operator Manual and inspect for wear, sharpness and cracking. Replace grinding cup wheel if severely worn or damaged.
5. Visually inspect Edge Grinder per MAINTENANCE INSTRUCTIONS STEPS 5 through 10 of this manual.

IMPORTANT: DO NOT use thinner, benzene, or other volatile solvents that can attack rubber/plastic components when cleaning Edge Grinder.

DANGER

- Use safety type solvent.
- Provide adequate ventilation.
- DO NOT smoke while using cleaning solvents.
- DO NOT use solvents with motor running or if it is hot.
- Allow ample time for motor to cool BEFORE using solvents.
- An ignition source in close proximity to hot motor can be source of an explosion, resulting in property damage and/or personal injury.

LUBRICATION

Intervals will vary dependent on machine use and operating environments. In general, lubrication should be performed after every 8 hours of continuous use.

Lubricants Required:

1 each, container dry film lubricant

1. Lubricate caster wheel bearing surfaces with dry film lubricant. DO NOT use other type lubricants that can attract foreign materials reducing service life.

ELECTRIC MOTOR SERVICE

The motor is designed for long service life with minimal maintenance and is equipped with higher capacity ball bearings/seals intended for dust-filled atmospheres that should not require lubrication for many years.

The motor features auto-stop carbon brushes. When brushes wear to a predetermined level, the motor will automatically shut off to prevent damage to the armature. Replacement brushes can only be installed by an authorized Metabo Service Center using Metabo replacement parts.

Metabo Service Contact Information:

Phone: 800.638.2264

Fax: 800.638.2261

Email: info@metabousa.com

You can also contact the General Equipment Company Customer Service Department for additional assistance.

Phone: 800.533.0524

Fax: 877.344.4375

Email: general@generalequip.com

13 TROUBLESHOOTING

NOTE: If troubleshooting information does not correct situation, all maintenance/repairs not described in this operator manual must be done by a dedicated service center following a specific service/repair manual.

MOTOR WILL NOT START OR LOOSES POWER

Possible Cause	Correction
ON/OFF switch located on operator handle in OFF position.	Turn to ON position.
ON/OFF switch located on power head in OFF position.	Turn to ON position.
High operating temperatures. Motor thermal protection activated.	Disconnect machine from power source. Allow to cool. Determine power head housing air vents are clean of foreign material accumulations. Clean as necessary using appropriate solvent.
Integral motor GFI tripped.	Inspect all cords for damage and proper connection configuration. Consult qualified electrician for potential ground fault in circuit.

Motor brushes reached predetermined wear point.	Contact Metabo Service Center for replacement service.
Operator handle cord plug to power head not connected.	Inspect for damage and proper connection configuration. Connect cord to power head cord.
No power received from power source.	Consult qualified electrician for proper voltage and ampere output.
Improper extension cord connection (if applicable).	Determine all connections produce a closed circuit. Reduce length and/or increase cord cross-sectional size.
Motor loses power.	Check power source for correct voltage and amperage.

7. Store Edge Grinder inside. If Edge Grinder must be stored outside, protect it with a suitable covering.

15 END OF LIFECYCLE



If the machine comes to the end of its lifecycle, destruction of the machine must be conducted according to international and local environmental regulations.

UNEVEN ACCESSORY GRINDING CUP WHEEL WEAR

Possible Cause	Correction
Incorrect grinding cup wheel installation.	See INSTALLING & REMOVING ACCESSORY GRINDING CUP WHEEL this manual.
Bent arbor shaft.	Contact Metabo Service Center for replacement service.
Bent grinding cup wheel.	Replace grinding cup wheel.
Caster wheels out of adjustment.	Adjust caster wheels.

EXCESSIVE JUMPING ON WORK SURFACE

Possible Cause	Correction
Incorrect grinding cup wheel installation.	See INSTALLING & REMOVING ACCESSORY GRINDING CUP WHEEL this manual.

UNEVEN WORK SURFACE MATERIAL REMOVAL

Possible Cause	Correction
Bent arbor shaft.	Contact Metabo Service Center for replacement service.
Bent grinding cup wheel.	Replace grinding cup wheel.
Excessive material build-up on caster wheel face surface.	Remove material. Readjust wheel scraper to wheel gap setting: .03/.06 inch (0.8/1.5 mm).
Caster wheels out of adjustment.	Adjust caster wheels.
Excessive axle shoulder-type cap screw wear.	Replace cap screw.

14 STORAGE

LONG TERM STORAGE



Procedure for long term storage of Edge Grinder will protect it against effects of corrosion and damage. If Edge Grinder is not to be operated for a period of 30 days or more, proceed to store as follows:

1. STOP Edge Grinder per STOPPING Edge Grinder in OPERATING INSTRUCTIONS section of this manual.
2. Remove accessory grinding cup wheel per INSTALLING & REMOVING ACCESSORY GRINDING CUP WHEEL in MACHINE SET-UP section of this manual. Store to prevent damage or rust.

CAUTION

- DO NOT store Edge Grinder accessory grinding cup wheel attached. This configuration can result in property damage and/or personal injury.

3. Clean Edge Grinder per MAINTENANCE INSTRUCTIONS section of this manual.
4. Inspect all visible parts for wear, breakage or damage per MAINTENANCE INSTRUCTIONS section of this manual.
5. Apply a dry film lubricant to all exposed metal components, including accessory grinding cup wheel, to prevent rust formation.
6. Block bottom of main frame to prevent damage to dust collection shield and arbor shaft.

*Replacement Parts Diagram
SG7 Edge Grinder
115VAC, 60HZ Operation*

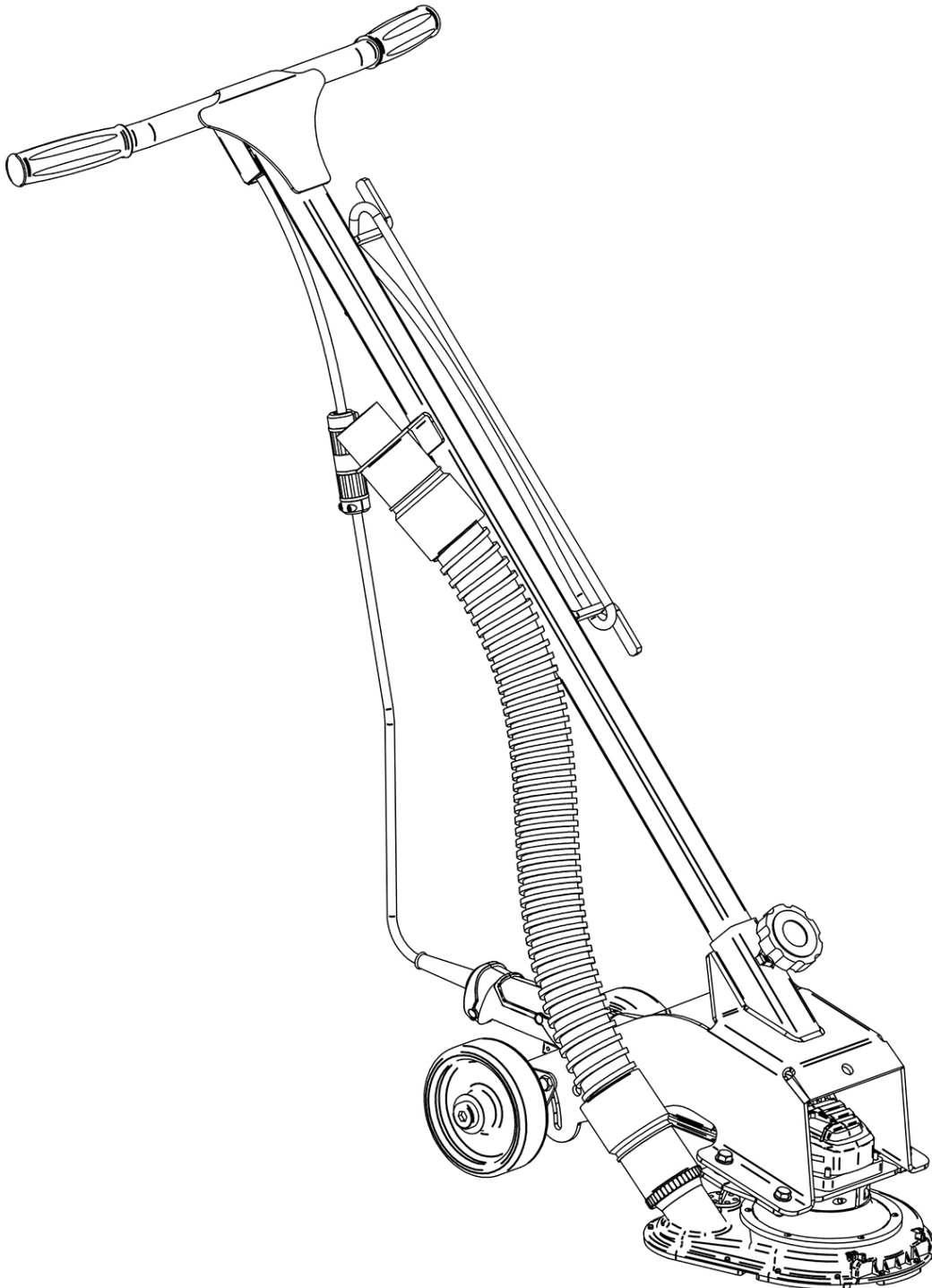

Replacement Parts Diagram Operator Handle Assembly SG7 Edge Grinder [Beginning with Serial Number 178775]

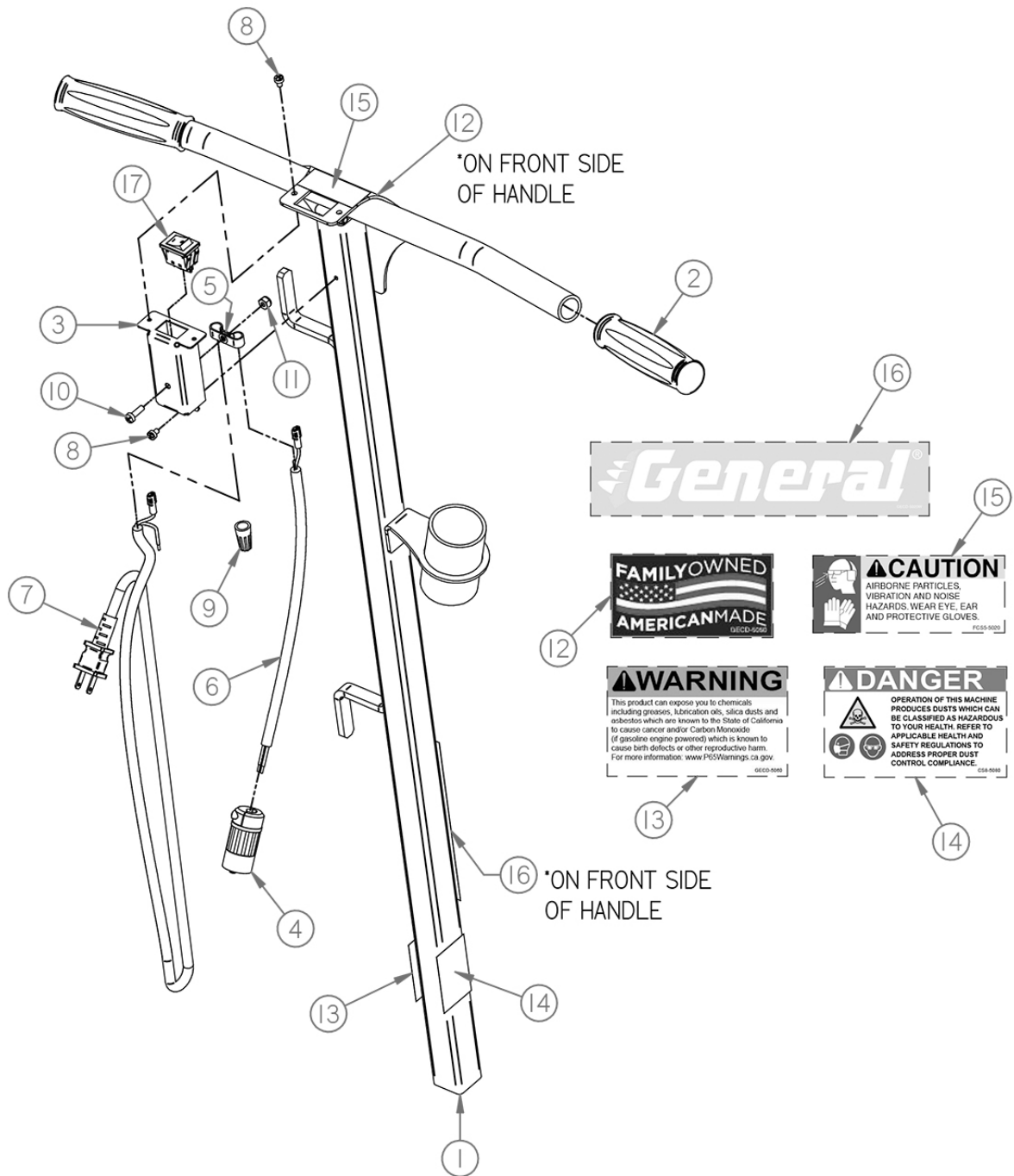

*Replacement Parts Diagram
 Operator Handle Assembly
 SG7 Edge Grinder
 [Beginning with Serial Number 178775]*

Reference Number	Part Number	Description	Quantity
1	SG7-0020	Weldment, Handle	1
2	FCS16-0290	Grip, Handle	2
3	SG7-0050	Housing, Switch	1
4	FCS10-0160	Recepticle, Cord, Female	1
5	FCS10-0170	Clamp, Wire	2
6	FCS10-0240	Cable, Switch To Plug	1
7	FCS10-0230	Cable, Plug To Switch	1
8	79020200	PHMS, Self Tap, #8-32 X 1/4	3
9	WIRENUTY	Nut, Wire	1
10	37030500	PHMS, #10-24 X 5/8, ZY	1
11	53030000	Nut, Nylok, #10-24, ZY	1
12	GECD-5050	Decal, Family Owned, American	1
13	GECD-5060	Decal, Warning, Prop 65	1
14	CS8-5080	Decal, Hazard, Dust	1
15	FCS5-5020	Decal, Caution	1
16	GECD-5020W	Decal, General, 1.38 X 7.00	1
17	SG7-0060	Power, Switch	1

Replacement Parts Diagram Main Frame Assembly SG7 Edge Grinder [Beginning with Serial Number 178775]

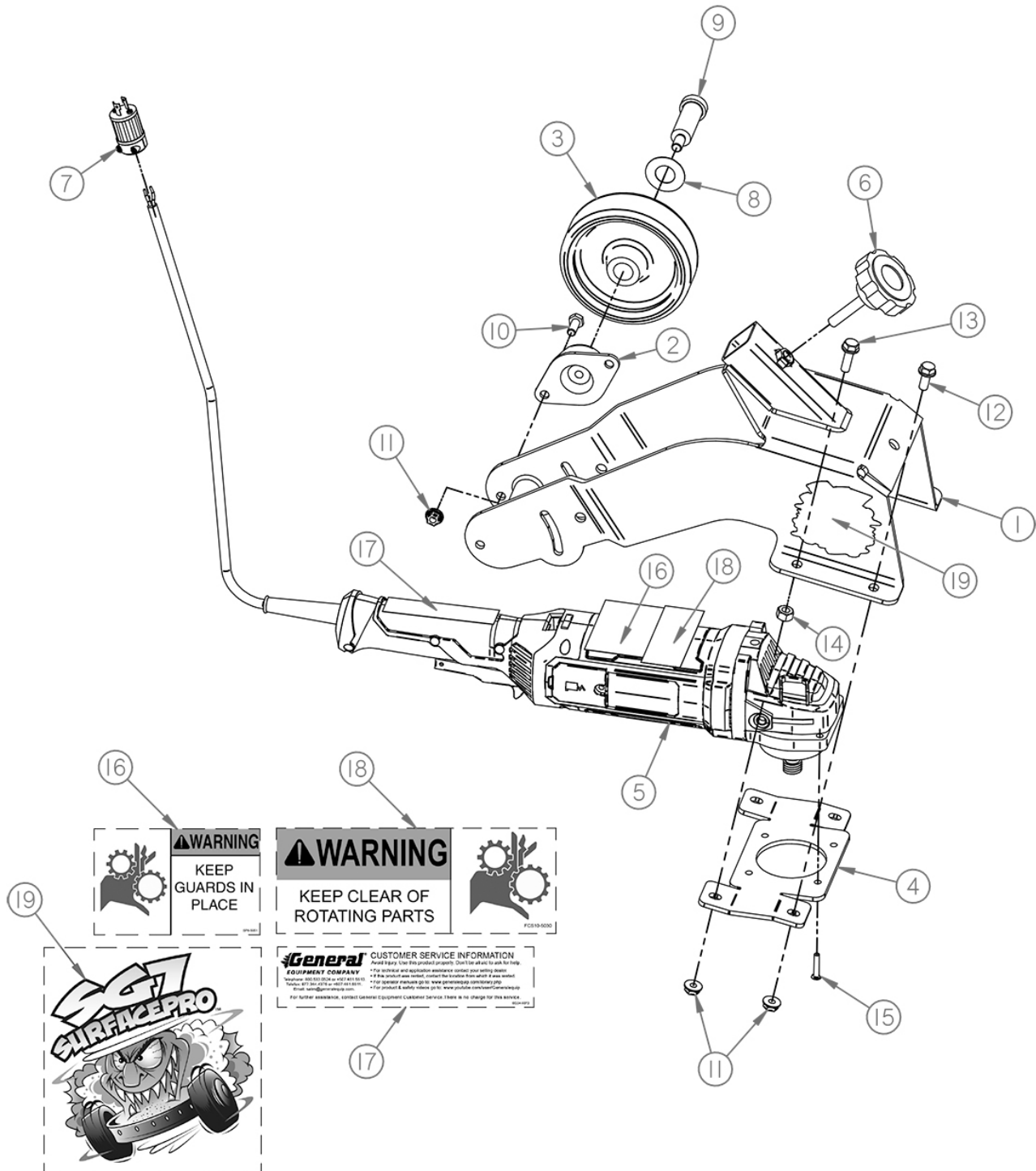

*Replacement Parts Diagram
 Main Frame Assembly
 SG7 Edge Grinder
 [Beginning with Serial Number 178775]*

Reference Number	Part Number	Description	Quantity
1	SG7-0010	Frame, Main	1
2	FCS10-0110	Mount, Rubber, Axle	2
3	FCS10-0190	Wheel, 5D	2
4	SG7-0030	Bracket, Adapter, Grinder	1
5	FCS10-0201	Grinder, Metabo	1
6	FCS16-0150	Knob, Adjustment	1
7	FCS10-0150	Plug, Cord, Male	1
8	200682	Washer, Plastic	2
9	FCS10-0210	Bolt, Shoulder, Special	2
10	15050600	HHCS, 5/16-18 X 3/4, ZY	4
11	39050000	Nut, Whizlock, 5/16-18, ZY	8
12	88050600	Bolt, Flange, 5/16-18 X 3/4	2
13	88050800	Bolt, Flange, 5/16-18 X 1	2
14	18060000	Nut, Hex, 3/8-16, ZY	2
15	37052510	PHMS, M5-0.8 X 25, Z	4
16	SP8-5051	Decal, Warning, Guards	1
17	SG24-5072	Decal, Assistance	1
18	FCS10-5030	Decal, Warning, Clear Rotating	1
19	SG7-5010	Decal, Surface Pro	2

*Replacement Parts Diagram
Grinder Accessories
SG7 Edge Grinder
[Beginning with Serial Number 178775]*

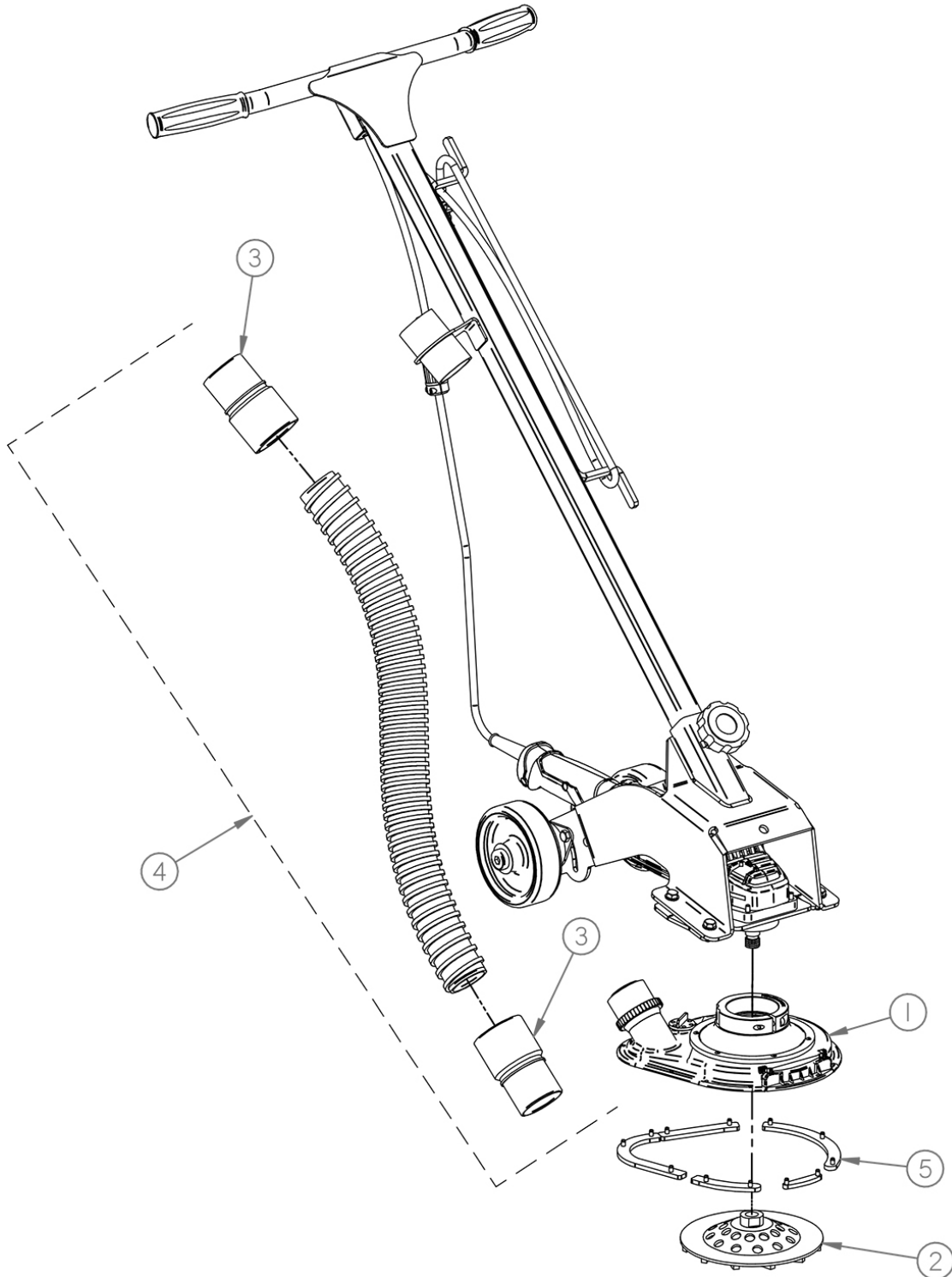

*Replacement Parts Diagram
Grinder Accessories
SG7 Surface Grinder
[Beginning with Serial Number 178775]*

Reference Number	Part Number	Description	Quantity
1	SG7-0080	Shroud, Dust, (Includes Ref. 5)	1
2	SG7-2000-30	Wheel, Diamond, 7D, G30	1
3	VS220-1100-030	Coupler, Helix, Plastic, 2D	2
4	SG7-0090	Hose, Helix, 2D, 25L, (Includes Ref. 3)	1
5	SG7-0080-050	Bars, Wear, Shroud	1