

7 Replacement Parts CTS12 RIP-R-STRIPPER

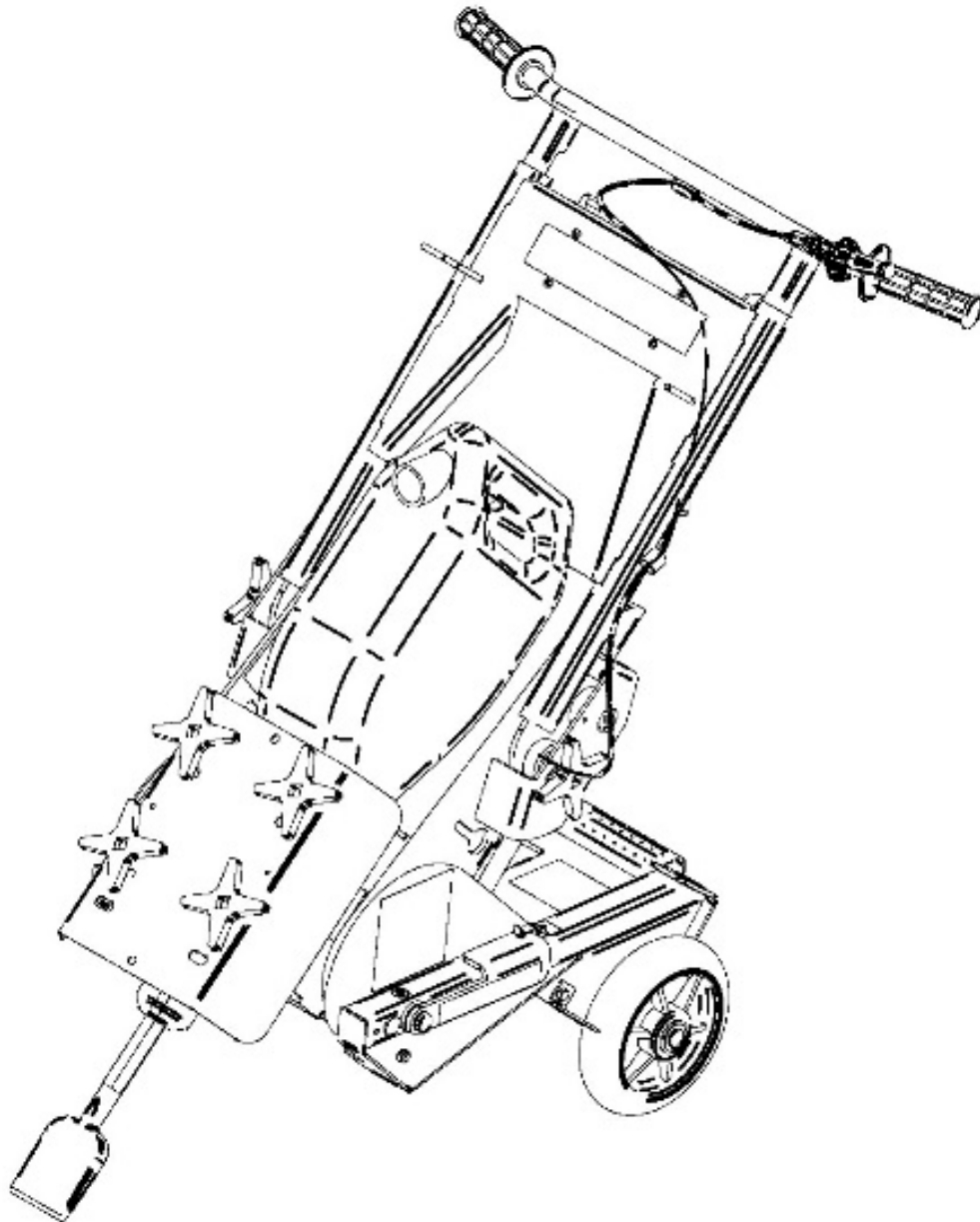

Replacement Parts Diagram Upper Handle Assembly [Up Through Serial Number 153105]

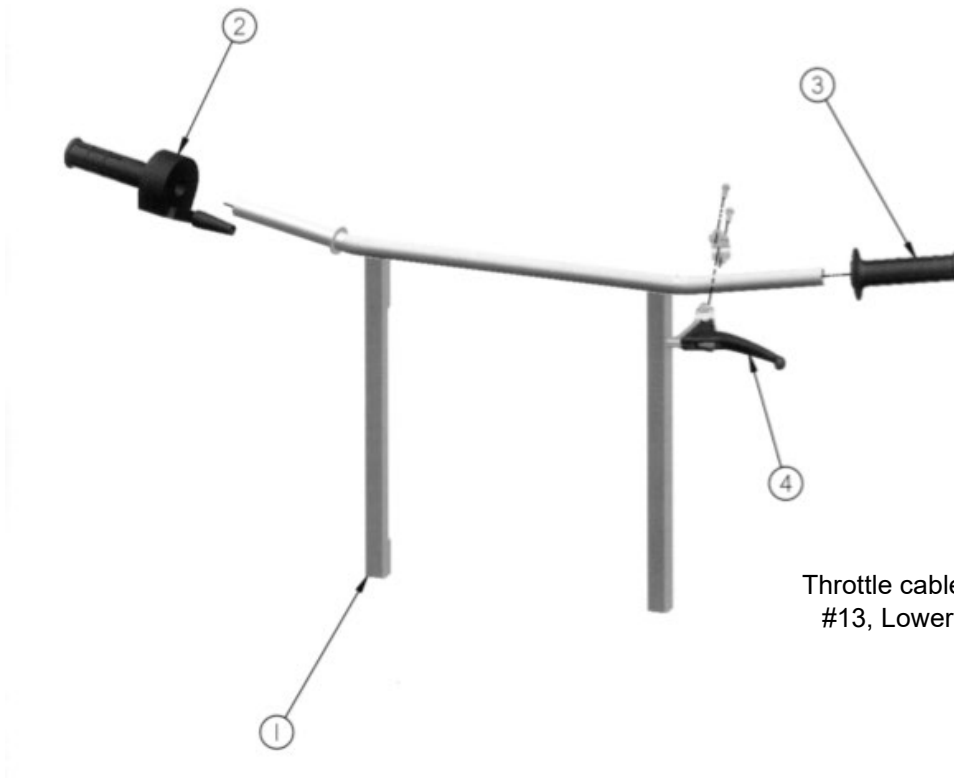

Throttle cable shown on page 42
 #13, Lower Handle Assembly

Reference Number	Part Number	Description	Quantity
1	SG12-0110	Weldment, Handle, Adjustable	1
2	310-0030	Assembly, Control, Throttle, Complete	1
3	SG12-0415	Grip, Handle	1
4	CTS12-0190	Assembly, Lever, Brake	1

Replacement Parts Diagram Plastic Body Series 314 Magura Throttle Control Assembly

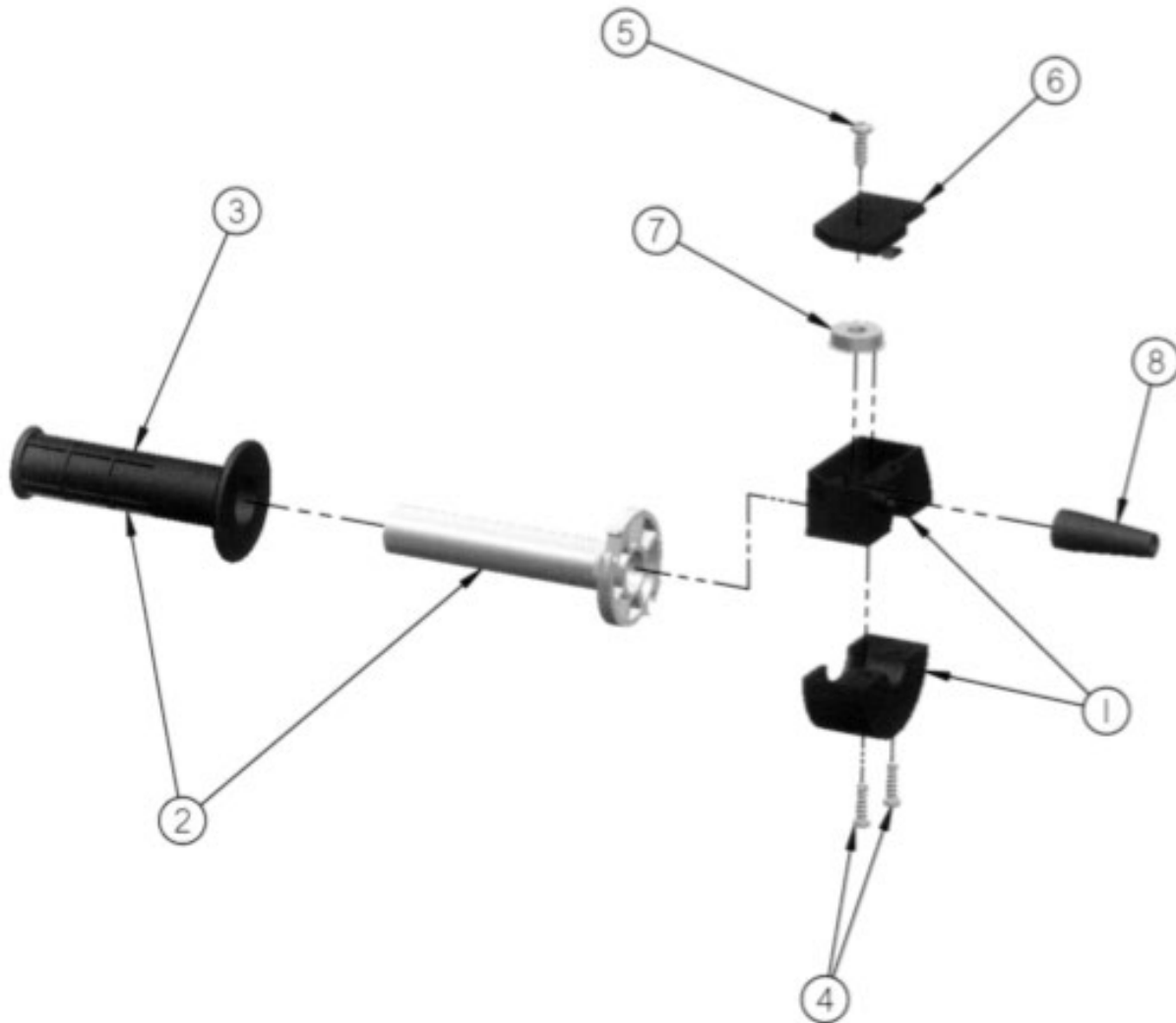

Reference Number	Part Number	Description	Quantity
1	310-0030-010-A	Assembly, Body, W/Screws (Includes P/N 310-0030-040, Qty 2)	1
2	310-0030-020-A	Tube, Throttle, W/Grip (Included P/N 310-0020-030)	1
3	310-0020-030	Grip, Throttle	1
4	310-0030-040	Screw, Head, PAM, M5 x 20	2
5	310-0030-050	Screw, Self Tapping	1
6	310-0030-060	Cover, Top	1
7	310-0030-070	Sheave, Roller	1
8	310-0030-080	Boot, Rubber	1

Replacement Parts Diagram Upper Handle Assembly [Starting with Serial Number 153106]

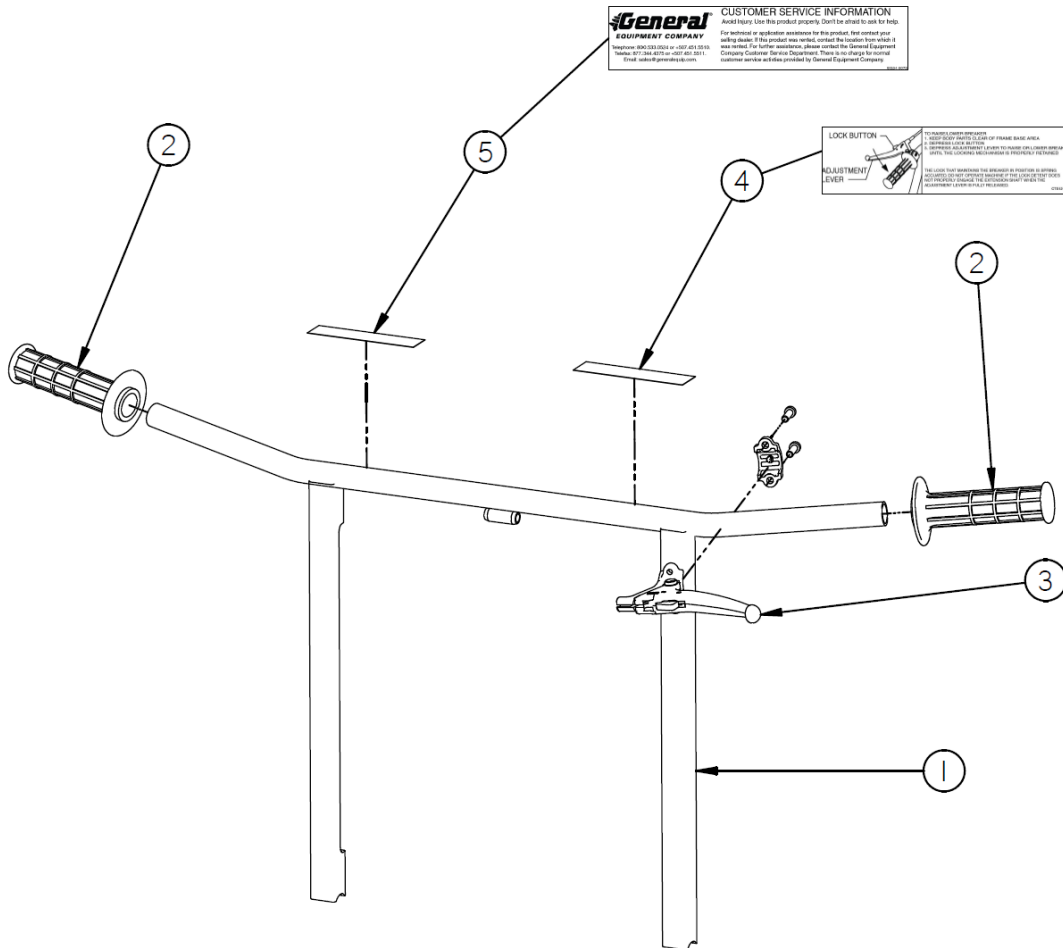

Reference Number	Part Number	Description	Quantity
1	SG12-0111	Weldment, Handle, Adjustable	1
2	SG12-0415	Grip, Handle	2
3	CTS12-0190	Assembly, Lever, Brake	1
4	CTS12-5020	Decal, Lever	1
5	SG24-5072	Decal, Assistance	1

Replacement Parts Diagram Lower Handle Assembly [Up Through Serial Number 153105]

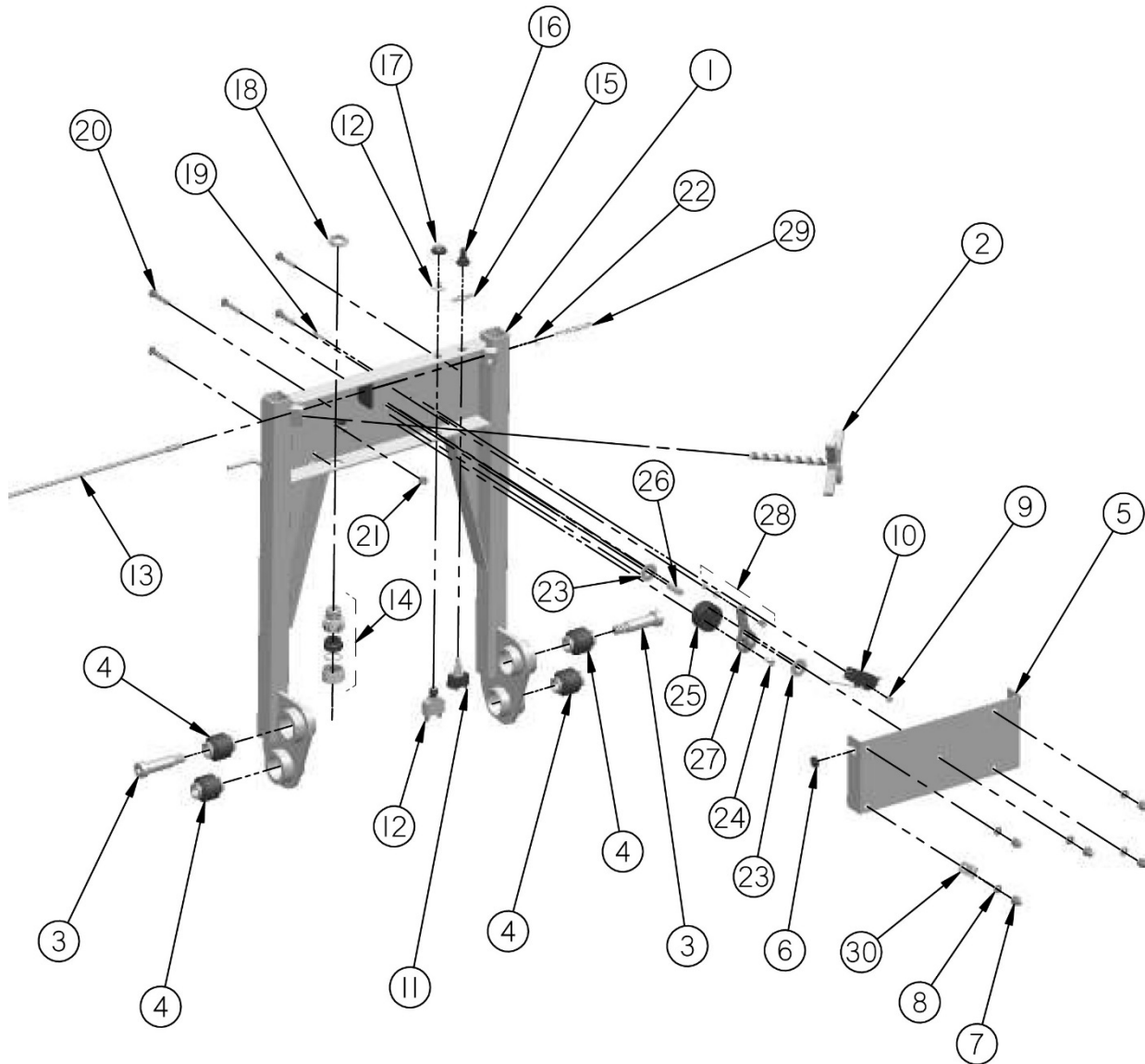

Replacement Parts Diagram Lower Handle Assembly [Up Through Serial Number 153105]

Reference Number	Part Number	Description	Quantity
1	CTS12-0050	Handle, Lower	1
2	SG12-0051	Weldment, Knob	2
3	62101400	Bolt, Shoulder, 5/8" x 1-1/4", Plated	2
4	CTS12-0280	Mount, Elastomeric	4
5	SG12-0191	Cover, Switch	1
6	FCS16-0300	Grommet, Rubber	1
7	90040000	Nut, Acorn, 1/4-20 UNC, Brass	5
8	16040000	Washer, Lock, 1/4", Plated	5
9	12010000	Nut, #6-32, K-Lock	2
10	SG12-0070	Switch	1
11	SG12-0300-010	Switch, Master	1
12	SG12-0080	Breaker, Circuit	1
13	310-0081	Cable, Throttle	1
14	CG-5050	Relief, Strain	2
15	SG12-0300-030	Plate, Face, Switch, Master	1
16	SG12-0300-020	Cover, Switch, Master	1
17	SG12-0090	Cover, Breaker, Circuit	1
18	801	Nut, Bulkhead	2
19	34010800	Screw, Machine, Head, Socket, #6 x 1", Plated	2
20	37041300	Screw, Machine, Head, - 1/4-20 UNC, x 1-5/8", Plated	5
21	18040000	Nut, Hexagon, 1/4-20 UNC, Plated	1
22	SG12-0340	Clip, E-Type	1
23	17060000	Washer, Flat, 3/8"	2
24	SG12-0170	Cam, Switch	2
25	SG12-0380	Screw, Wood, Flat Head	1
26	SG12-0150	Tube, Pivot	1
27	SG12-0160	Lever, Switch	1
28	WS277	Swivel	1
29	SG12-0350	Spring, Compression	1
30	COV-0411	Clamp	1

Replacement Parts Diagram Lower Handle Assembly [Starting with Serial Number 153106]

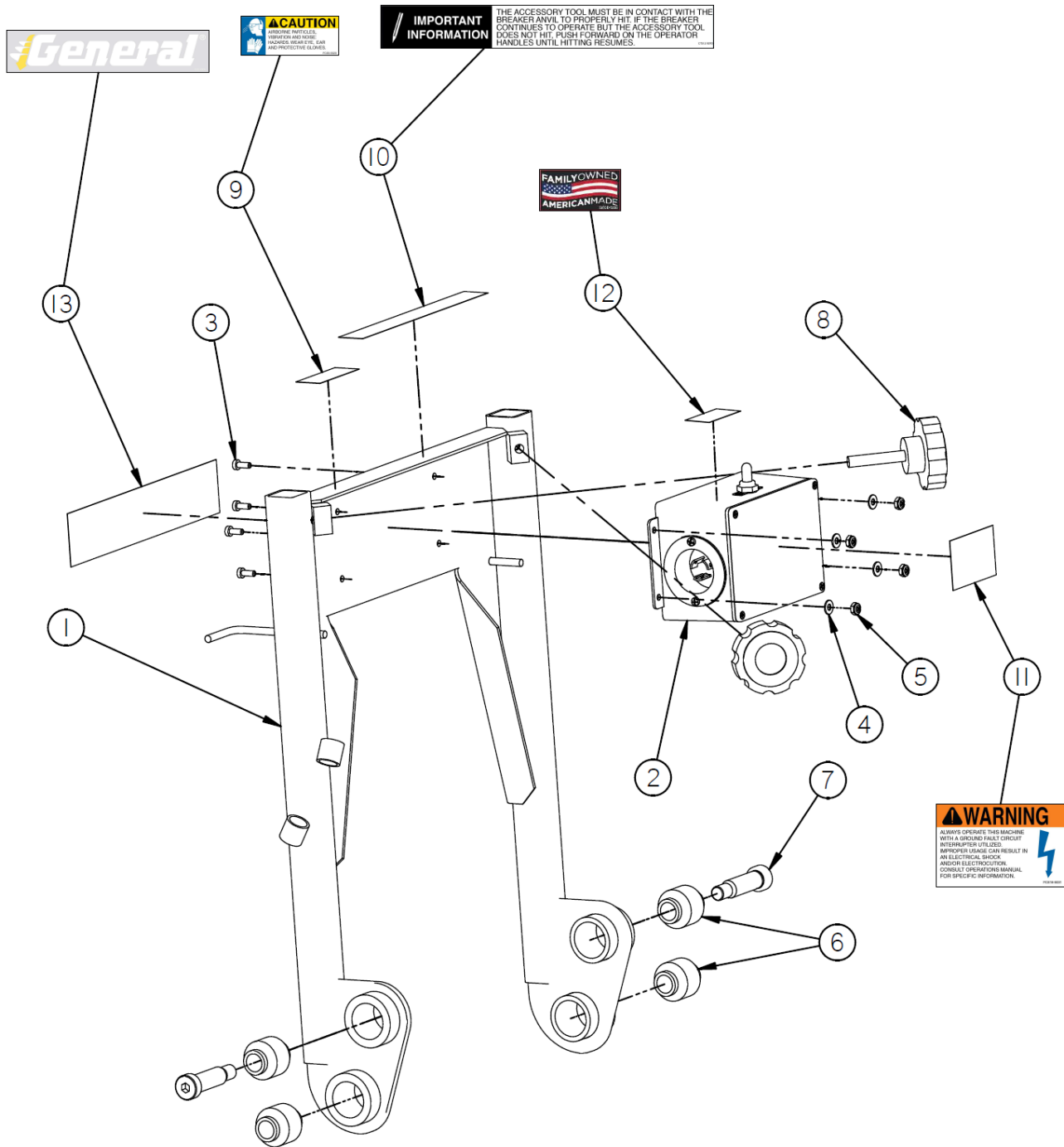

*Replacement Parts Diagram
 Lower Handle Assembly
 [Starting with Serial Number 153106]*

Reference Number	Part Number	Description	Quantity
1	CTS12-0051	Handle, Lower	1
2	CTS12-0481A	Assy, Enclosure, Electric, US	1
3	37030400	PHMS, 10-24 X 1/2, ZY	4
4	17030000	Washer, Flat, Light, No 10, ZY	4
5	53030000	Nut, Hex, Nylok, 10-24, ZY	4
6	CTS12-0280	Mount, Rubber, 60 Durometer	4
7	62101400	Bolt, Shldr, 5/8 X 1-3/4, ZY	2
8	FCS16-0150	Knob, Adjustment	2
9	FCS5-5020	Decal, Caution	1
10	CTS12-5070	Decal, Operation	1
11	FCS16-5031	Decal, Warning, Shock	1
12	GECD-5050	Decal, Family Owned, American	1
13	GECD-5030W	Decal, General, 1-7/8 X 9-1/2	1

Replacement Parts Diagram Wiring Diagram [Up Through Serial Number 153105]

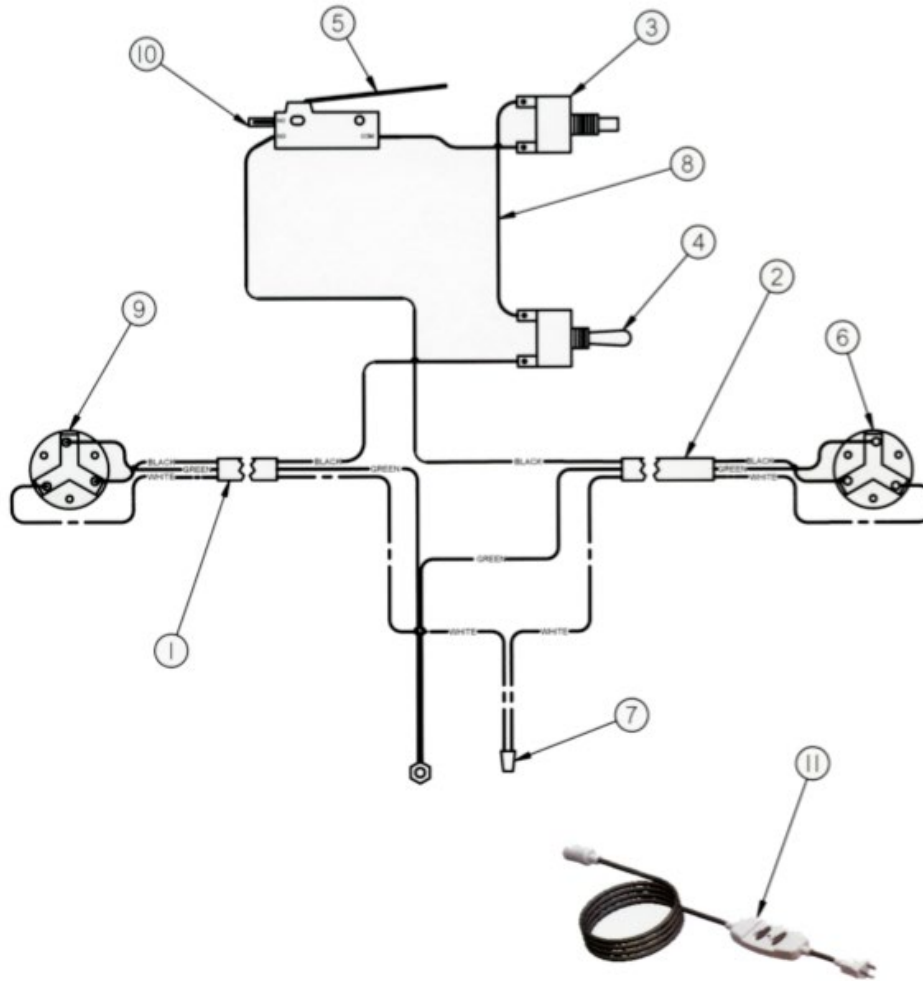

Reference Number	Part Number	Description	Quantity
1	CTS12-0480A	Cable, Electrical, Assembly (Male Plug to Switch)	1
2	CTS12-0470A	Cable, Electrical, Assembly (Switch to Female Plug)	1
3	SG12-0080	Circuit Breaker, 15 AMP	1
4	SG12-0300-010	Switch, Master Toggle	1
5	SG12-0070	Switch, 115V	1
6	CTS12-0340	Receptacle, Cord, Female, 5269C	1
7	WIRE NUT Y	Nut, Wire	1
8	SG12-0290A	Wire, Jumper	1
9	HUB-4720C	Plug, Twist Lock, Male, 15A	1
10	SG12-0320	Sleeve, Protective	1
11	FCS16-1000	Extension Cord, GFCI	1

*Replacement Parts Diagram
US Electrical Control Enclosure
CTS12-0481A
[Starting with Serial Number 153106]*

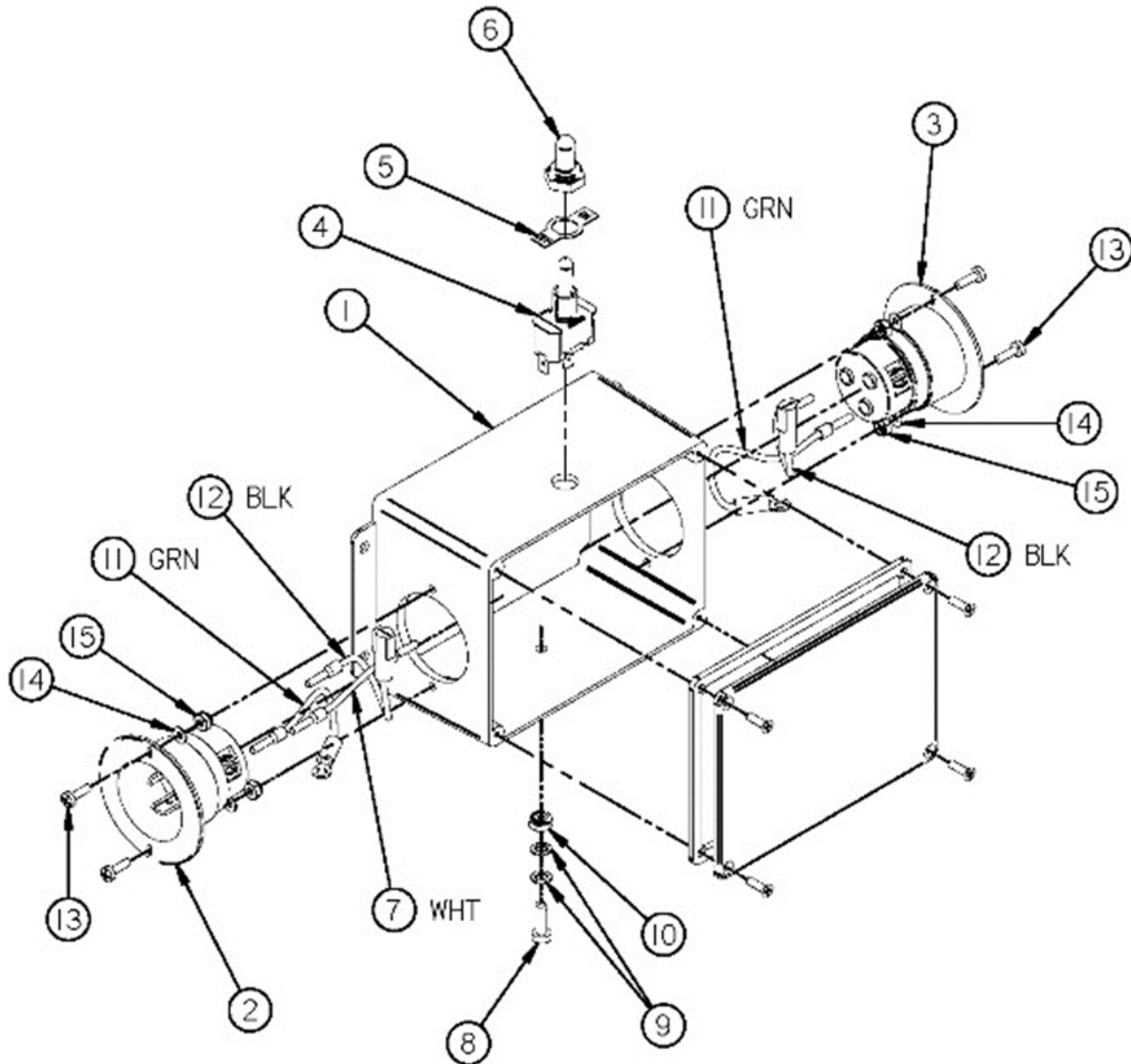

Replacement Parts Diagram
US Electrical Control Enclosure
CTS12-0481A
[Starting with Serial Number 153106]

Reference Number	Part Number	Description	Quantity
1	CTS12-0481-010	Enclosure, Electrical	1
2	CTS12-0481-020	Inlet, Electric, Nema L5-15P	1
3	CTS12-0481-030	Outlet, Electric, Nema 5-15R	1
4	SG12-0300-010	Switch, Master	1
5	SG12-0300-030	Plate, Face, Switch, Master	1
6	SG12-0300-020	Cover, Switch	1
7	CTS12-0481-060	Assembly, Wire, Neutral	1
8	37030500	PHMS, 10-24 X 5/8	1
9	58030000	Washer, Lock, Internal, Serrated	2
10	53030000	Nut, Hex, Nylok, 10-24, ZY	1
11	CTS12-0481-050	Assembly, Wire, Ground	2
12	CTS12-0481-040	Assembly, Wire, Line	2
13	37010400	PHMS, 6-32 X 1/2	4
14	17010000	Washer, Flat, No 6	4
15	1801000	Nut, Hex, No 6-32	4

Wiring Schematic

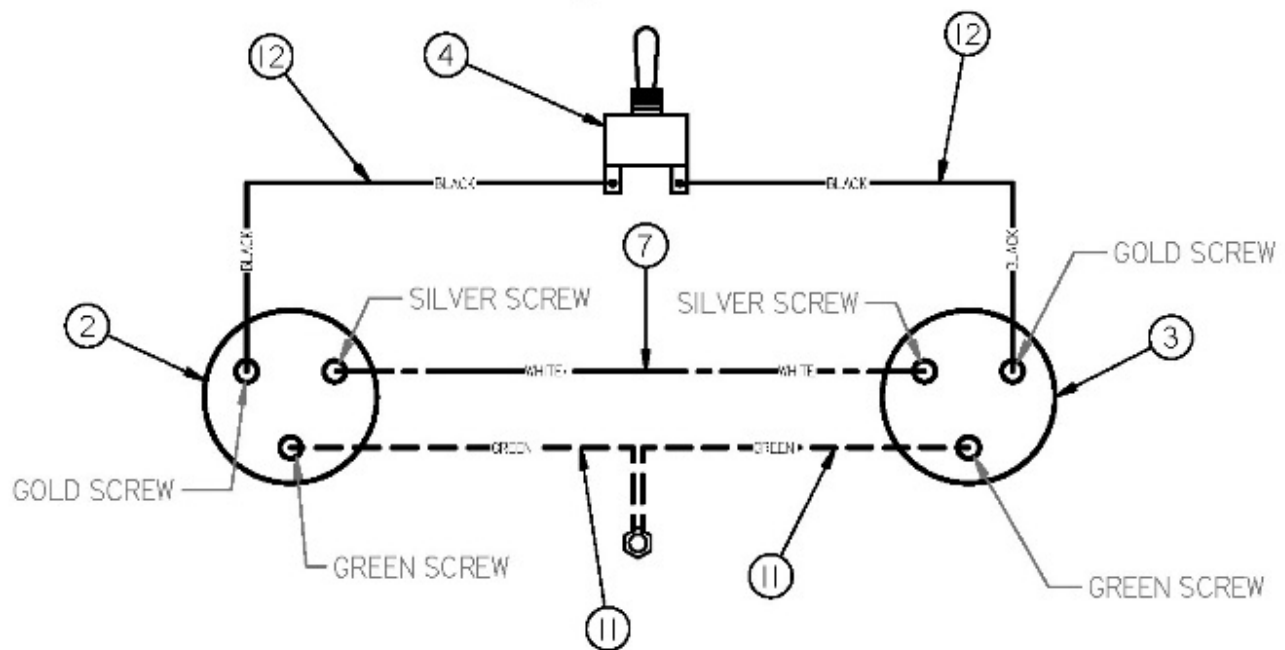

Replacement Parts Diagram Latch Tube Assembly [Up Through Serial Number 141417]

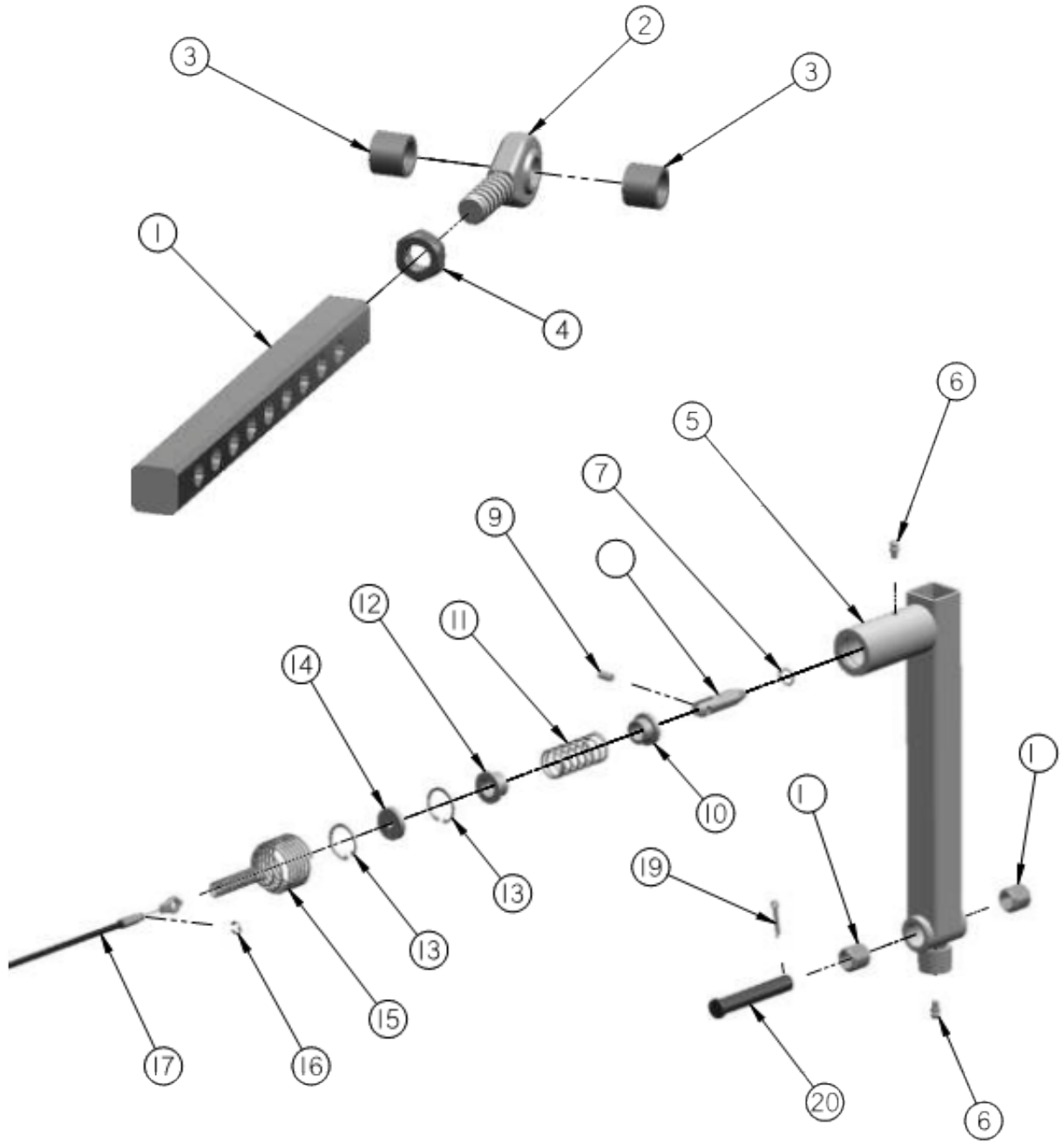

Replacement Parts Diagram Latch Tube Assembly [Up Through Serial Number 141417]

Reference Number	Part Number	Description	Quantity
1	CTS12-0090	Bar, Latch	1
2	SP8-0180	End, Rod, Male	1
3	CTS12-0170	Tube, Spacer	2
4	40100011	Nut, Jam, 5/8-11 UNC, LH, Plated	1
5	CTS12-0120	Weldment, Tube, Base	1
6	550-0590	Fitting, Grease	2
7	CTS12-0290	Ring, Snap, External, 0.5" ID	1
8	CTS12-0130	Pin, Latch	1
9	20040400	Pin, Roll, 1/4" x 1/2"	1
10	CTS12-0150	Guide, Pin, Inboard	1
11	CTS12-0260	Spring, Compression	1
12	CTS12-0160	Guide, Pin, Outboard	1
13	CTS12-0270	Ring, Snap, Internal. 1.0 ID	2
14	CTS12-0140	Mount, Cable	1
15	CTS12-0370	Spring, Support	1
16	SG12-0340	Clip, E-Type	1
17	CTS12-0080	Cable, Adjustment	1
18	CTS12-0360	Bushing, Spring-Type, 0.5 ID	2
19	22000800	Pin, Cotter, 5/32" x 1"	1
20	CTS12-0210	Pin, Clevis, 1/2" x 3", Plated	1

Replacement Parts Diagram Latch Tube Assembly [Starting with Serial Number 141418]

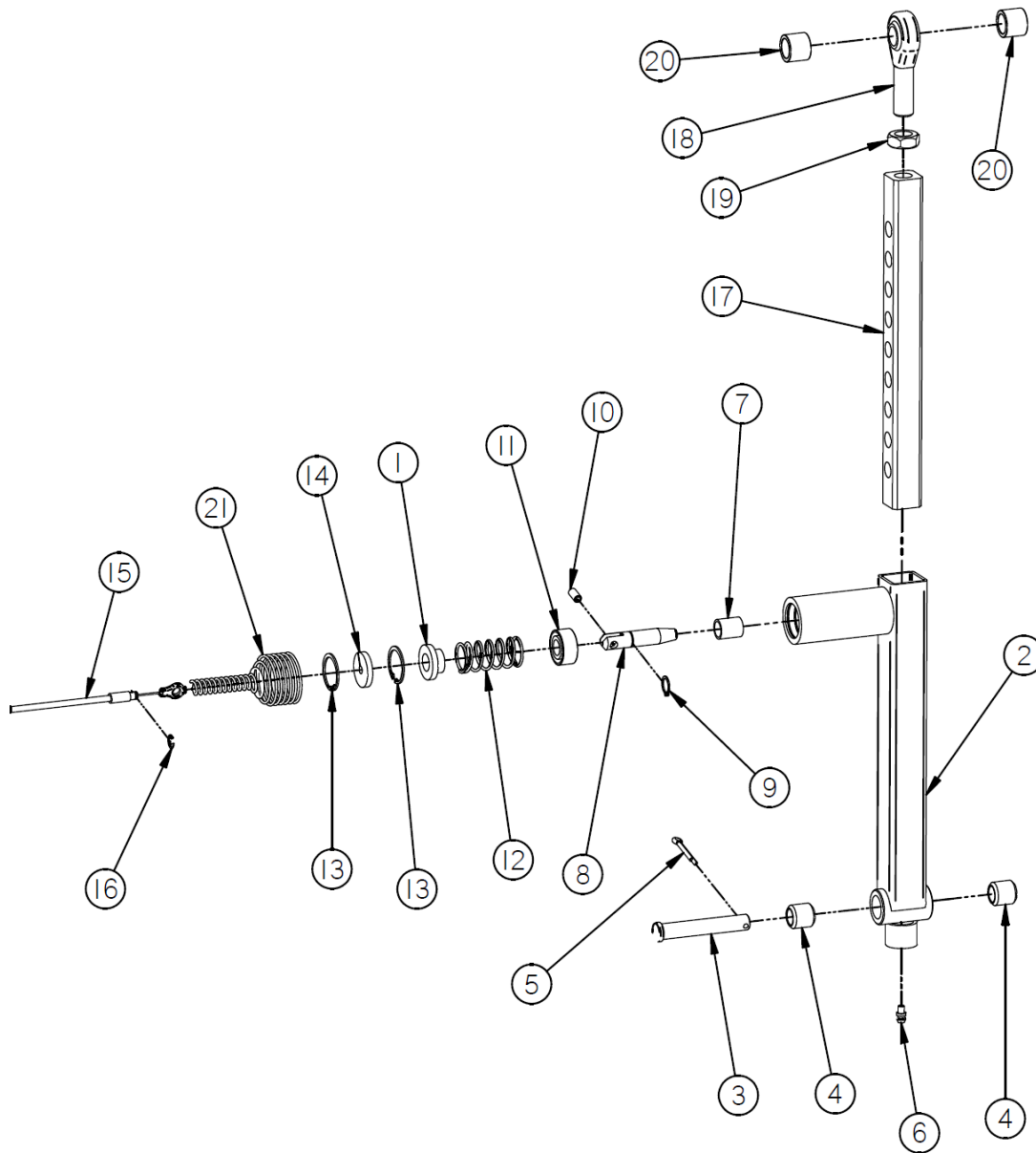

*Replacement Parts Diagram
 Latch Tube Assembly
 [Starting with Serial Number 141418]*

Reference Number	Part Number	Description	Quantity
1	CTS12-0161	Guide, Pin, Outer	1
2	CTS12-0121	Tube, Support	1
3	CTS12-0210	Pin, Clevis, 1/2 X 3, ZY	1
4	CTS12-0360	Bushing, Spring-Type	2
5	22000800	Pin, Cotter, 5/32 X 1.0	1
6	550-0590	Fitting, Grease	1
7	CTS12-0610	Bushing, Oilite, 0.5 ID	1
8	CTS12-0131	Pin, Latch	1
9	CTS12-0290	Ring, Snap, External, .5 D	1
10	20040400	Pin, Roll, 1/4 X 1/2	1
11	CTS12-0151	Pin, Guide, Inner	1
12	CTS12-0261	Spring, Compression	1
13	CTS12-0271	Ring, Snap, Internal, 1.125 D	2
14	CTS12-0141	Mount, Cable	1
15	CTS12-0080	Cable, Adjustment	1
16	SG12-0340	Clip, E-Type	1
17	CTS12-0091	Bar, Latch	1
18	SP8-0180	End, Rod, Male	1
19	40100011	Nut, Jam, 5/8-18, LH	1
20	CTS12-0170	Tube, Spacer	2
21	CTS12-0370	Spring, Support	1

Replacement Parts Diagram Upper Frame Assembly

WARNING
BEFORE HOISTING THIS MACHINE
CONSULT THE APPLICABLE
OPERATOR MANUAL. IMPROPER
HOISTING PROCEDURES CAN RESULT
IN PROPERTY DAMAGE AND/OR
PERSONAL INJURY.

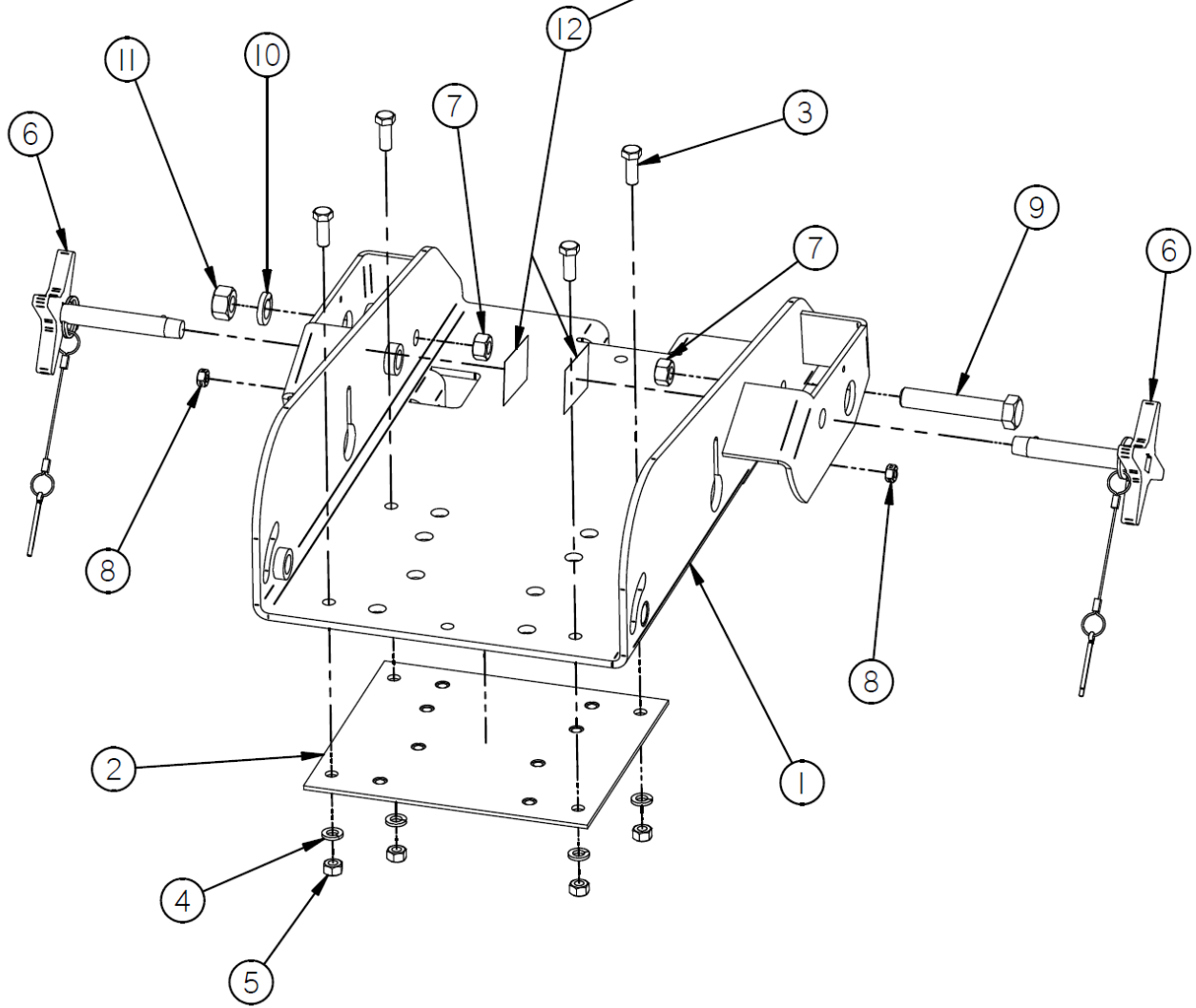

Replacement Parts Diagram Upper Frame Assembly

Reference Number	Part Number	Description	Quantity
1	CTS12-0110	Weldment, Plate, Hammer	1
2	CTS12-0060	Plate, Attachment	1
3	15060800	HHCS, 3/8-16 X 1, G5, ZY	4
4	1606000	Washer, Lock, 3/8, ZY	4
5	18060000	Nut, Hex, 3/8-16, ZY	4
6	CTS12-0250A	Assembly, Pin, Detent	2
7	52080000	Nut, Lock, 2-Way, 1/2-13, ZY	2
8	52050000	Nut, Lock, 2-Way, 5/16-20, ZY	2
9	15102800	HHCS, 5/8-11 X 3-1/2, G5, ZY	1
10	16100000	Washer, Lock, 5/8, ZY	1
11	18100000	Nut, Hex, 5/8-11, ZY	1
12	CS8-5051	Decal, Warning, Hoisting	2

Replacement Parts Diagram Lower Frame Assembly [Up Through Serial Number 153105]

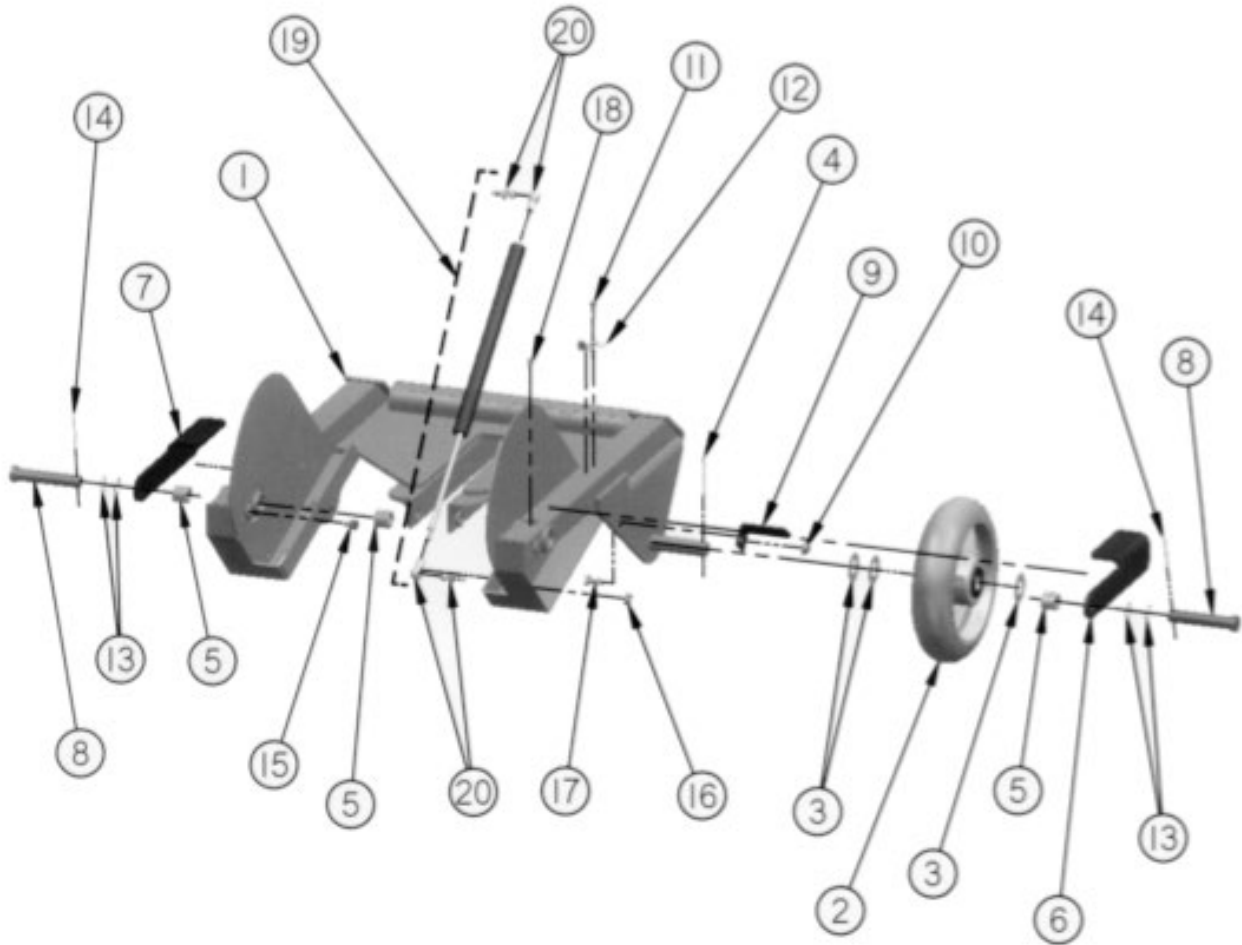

Replacement Parts Diagram Lower Frame Assembly [Up Through Serial Number 153105]

Reference Number	Part Number	Description	Quantity
1	CTS12-0100	Weldment, Frame	1
2	CTS12-0600	Wheel	2
3	200682	Washer, Plastic	6
4	22021200	Pin, Cotter, 1/8" x 1-1/2"	2
5	CTS12-0350	Bushing, Spring-Type, .62 ID	4
6	CTS12-0430	Stand, Kick, LH	1
7	CTS12-0440	Stand, Kick, RH	1
8	CTS12-0200	Pin, Clevis, 5/8" x 3", ZY	2
9	FCS16-0090	Scraper, Wheel	2
10	39050000	Nut, Hexagon, Flange, 5/16-18 UNC, Plated	2
11	60030500	Screw, Cap, Socket, #10-24 x 5/8", Plated	2
12	CTS12-0460	Latch, Down, Snap	2
13	CTS12-0450	Washer, Wave, .62 ID	4
14	22000800	Pin, Cotter, 5/32" x 1", Plated	2
15	60050300	Screw, Cap, Socket, 5/16-18 x 3/8", Plated	2
16	52050000	Nut, Lock, 2-Way, 5/16-18 UNC, Plated	2
17	15050600	Screw, Cap, 5/16-18 UNC x 3/4", Plated	2
18	550-0590	Fitting, Grease	2
19	CTS12-0220A	Assembly, Spring, Gas (Includes 2 of Part Number CTS12-0220-010)	2
20	CTS12-0220-010	Kit, Mounting, Spring, Gas (Includes 1 Ball Socket and 1 ball Stud)	4

Replacement Parts Diagram Lower Frame Assembly [Starting With Serial Number 153106]

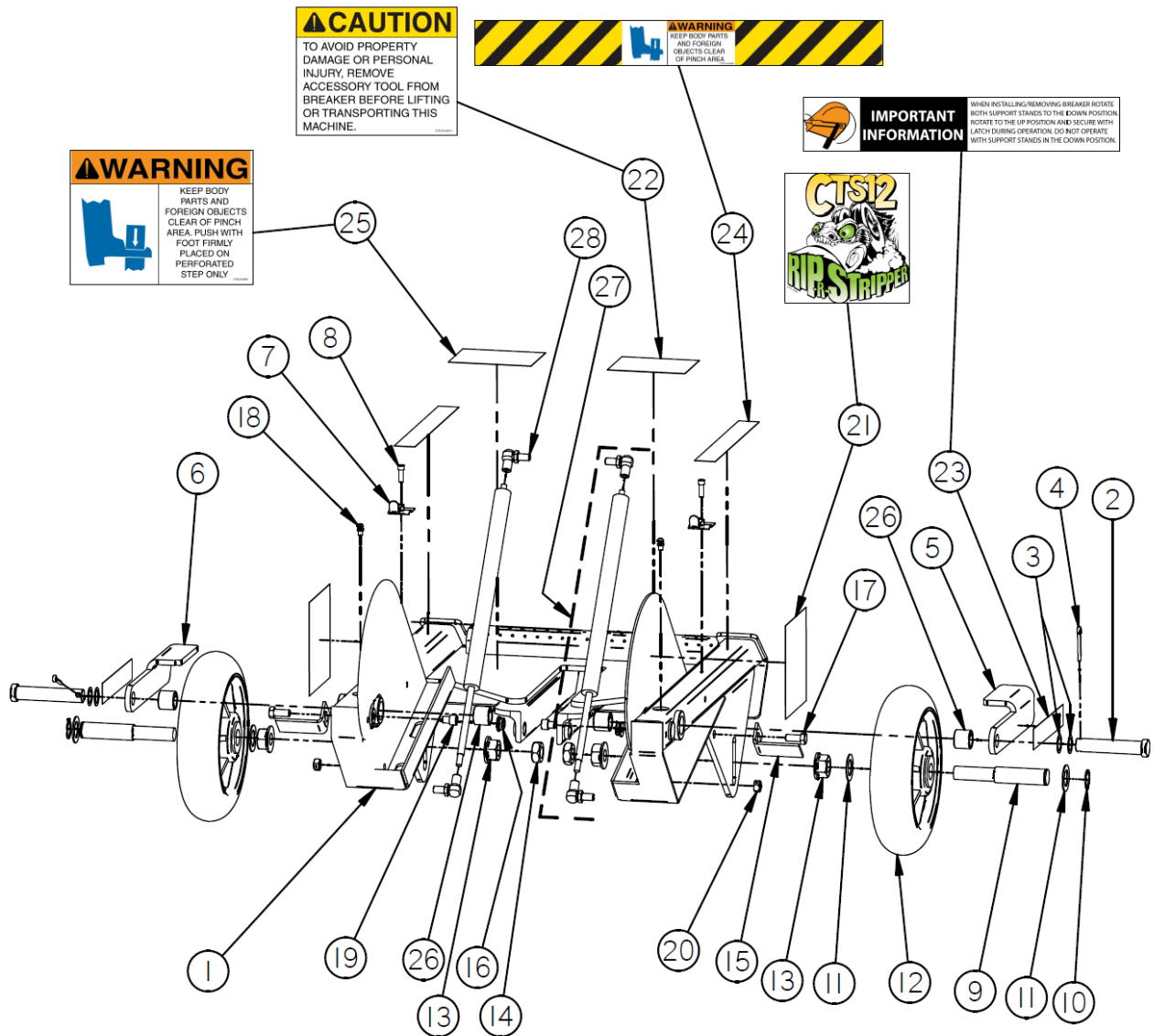

*Replacement Parts Diagram
Lower Frame Assembly
[Starting with Serial Number 153106]*

Reference Number	Part Number	Description	Quantity
1	CTS12-0101	Weldment, Frame	1
2	CTS12-0200	Pin, Clevis, 5/8 X 3, ZY	2
3	CTS12-0450	Washer, Wave, 5/8	4
4	22000800	Pin, Cotter, 5/32 X 1.0	2
5	CTS12-0430	Stand, Kick, Left Hand	1
6	CTS12-0440	Stand, Kick, Right Hand	1
7	CTS12-0460	Latch, Down, Snap	2
8	60030500	SHCS, 10-24 X 5/8, ZY	2
9	CTS12-0580	Axle, Wheel	2
10	5160-075	Ring, Snap, External, 3/4D	2
11	85120001	Bushing, Machine, 3/4NR	4
12	CTS12-0600	Wheel, 8 X 2	2
13	86100001	Nut, Hex, Flange, 5/8-18, ZY	4
14	40100001	Nut, Jam, Hex, 5/8-18, ZY	2
15	FCS16-0090	Scraper, Wheel	2
16	39050000	Nut, Whizlock, 5/16-18, ZY	2
17	15050600	HHCS, 5/16-18 X 3/4	2
18	550-0590	Fitting, Grease	2
19	60050300	SHCS, 5/16-18 X 3/8, ZY	2
20	52050000	Nut, Lock, 2-Way, 5/16-20, ZY	2
21	CTS12-5050	Decal, Rip-R-Stripper (CTS12)	2
22	CTS12-5010	Decal, Transport	1
23	CTS12-5060	Decal, Kickstand	2
24	CTS12-5040	Decal, Feet Clear	2
25	CTS12-5030	Decal, Push	1
26	CTS12-0350	Bushing, Spring-Type	4
27	CTS12-0220A	Spring, Gas, 130 Lbs, Complete	2
28	CTS12-0220-010	Kit, Mounting, Spring, Gas	4

Replacement Parts Diagram Breaker Mount Assembly Bosch® 11335K, GSH 16-28

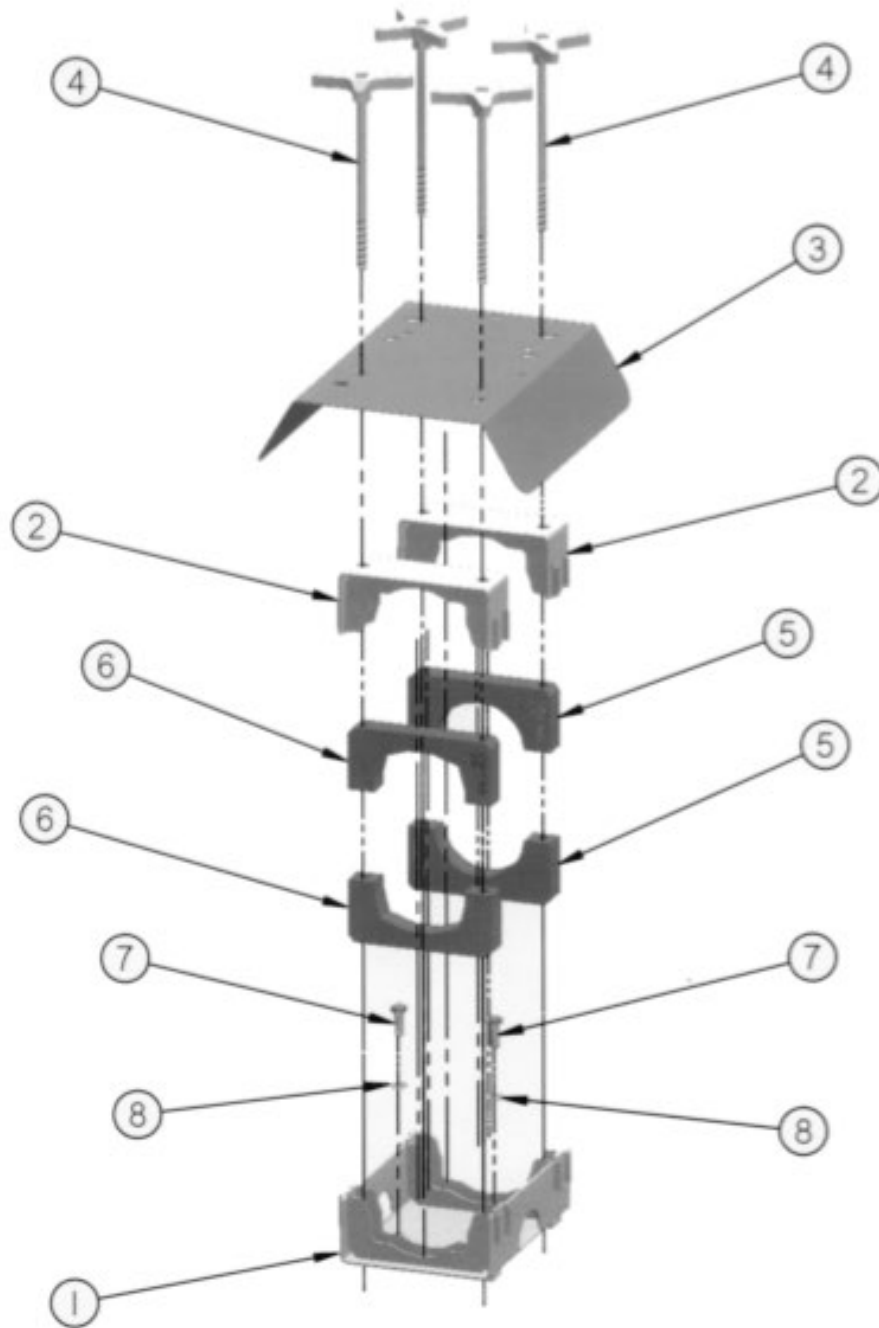

Replacement Parts Diagram
Breaker Mount Assembly
Bosch® 11335K, GSH 16-28

Reference Number	Part Number	Description	Quantity
1	CTS12-1200	Weldment, Mount, Base	1
2	CTS12-1001	Weldment, Clamp, CAP	2
3	CTS12-0040	Cover, Hammer	1
4	CTS12-0075	Screw, Clamp, 7.58" L	4
5	CTS12-0320	Block, Clamp, Elastomeric, 11335K, GSH 16-28, Bosch®	2
6	CTS12-0330	Block, Clamp, Elastomeric 11335K, GSH 16-28, Bosch®	2
7	15061000	Screw, Cap, 3/8-16 UNC x 1-1/4", Plated	2
8	16060000	Washer, Lock, 3/8", Plated	2

Replacement Parts Diagram Breaker Mount Assembly DeWalt® D25960K

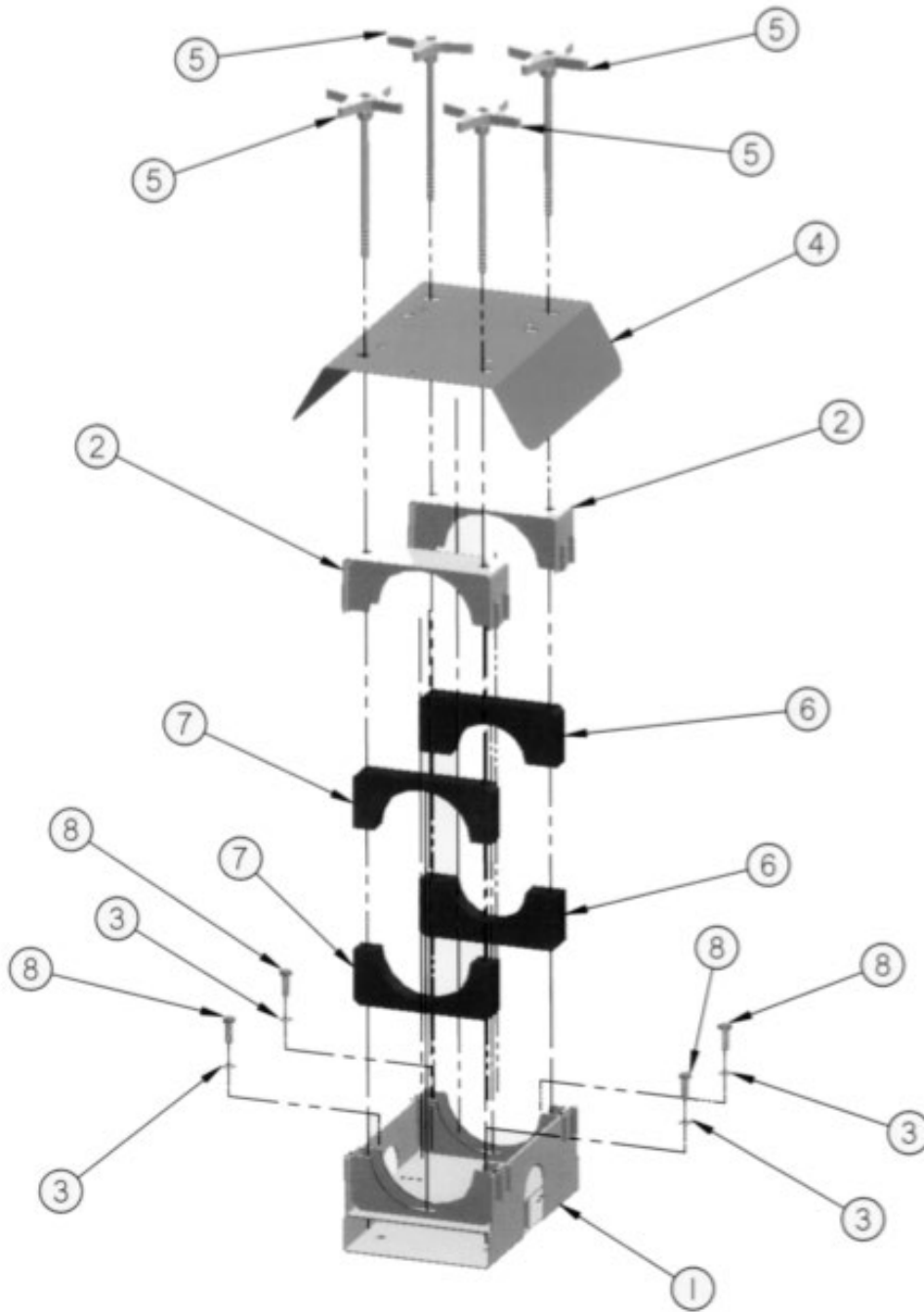

Replacement Parts Diagram
Breaker Mount Assembly
DeWalt® D25960K

Reference Number	Part Number	Description	Quantity
1	CTS12-1700	Weldment, Mount, Base	1
2	CTS12-1701	Weldment, Clamp, Cap	2
3	16060000	Washer, Lock, 3/8", Plated	4
4	CTS12-0040	Cover, Hammer	1
5	CTS12-0070	Screw, Clamp 7.08" L	4
6	CTS12-0530	Block, Clamp, Elastomeric D25960K, DeWalt®, 1-3/4" Radius	2
7	CTS12-0520	Block, Clamp, Elastomeric D25960K, DeWalt®, 2-1/4" Radius	2
8	15060800	Screw, Cap, 3/8-16 UNC x 1-1/4", Plated	4

Replacement Parts Diagram Breaker Mount Assembly Hilti® TE 905-AVR

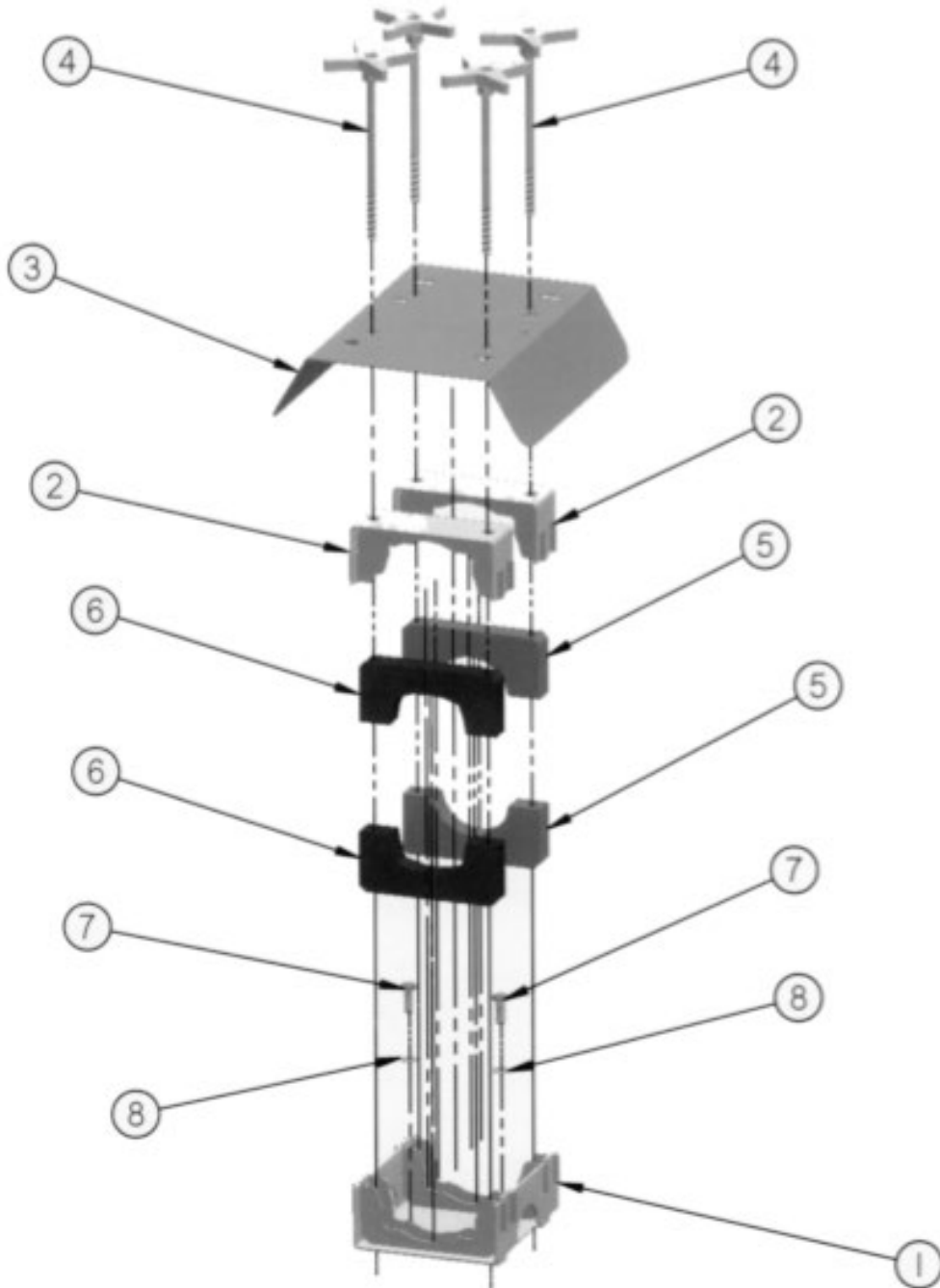

*Replacement Parts Diagram
 Breaker Mount Assembly
 Hilti® TE 905-AVR*

Reference Number	Part Number	Description	Quantity
1	CTS12-1000	Weldment, Mount, Base	1
2	CTS12-1001	Weldment, Clamp, Cap	2
3	CTS12-0040	Cover, Hammer	1
4	CTS12-0075	Screw, Clamp, 7.62 L	4
5	CTS12-0310	Block, Clamp, Elastomeric TE 905-AVR, Hilti®	2
6	CTS12-0380	Block, Clamp, Elastomeric TE 905-AVR, Hilti®	2
7	15061000	Screw, Cap, 3/8-16 UNC x 1-1/4", Plated	2
8	16060000	Washer, Lock, 3/8", Plated	2

*Replacement Parts Diagram
 Breaker Mount Assembly
 Hilti® TE 1000-AVR*

Reference Number	Part Number	Description	Quantity
1	CTS12-1410	Weldment, Mount, Base	1
2	CTS12-0400	Block, Clamp	1
3	CTS12-0391	Block, Clamp	1
4	CTS12-1403	Weldment, Clamp	1
5	CTS12-1404	Weldment, Clamp	1
6	CTS12-0570	Block, Clamp	1
7	CTS12-0620	Block, Clamp	1
8	15060800	HHCS, 3/8-16 X 1, G5, ZY	4
9	1606000	Washer, Lock, 3/8, ZY	4
10	CTS12-0075	Clamp, Screw	4
12	CTS12-0040	Cover, Hammer	1
13	CTS12-5080	Decal, Mount Locator	1

Replacement Parts Diagram Breaker Mount Assembly Hitachi® H65SD2

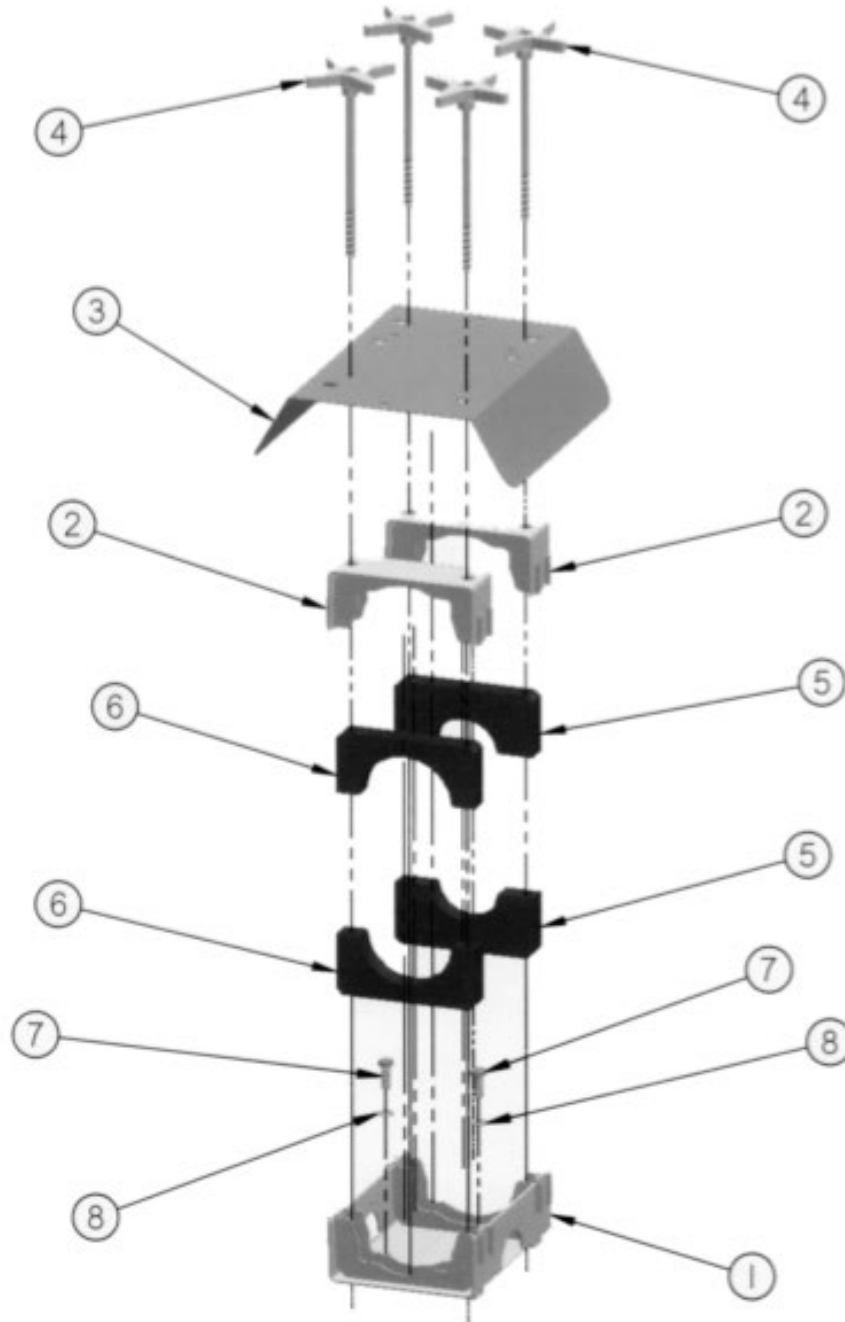

Replacement Parts Diagram
Breaker Mount Assembly
Hitachi® H65SD2

Reference Number	Part Number	Description	Quantity
1	CTS12-1200	Weldment, Mount, Base	1
2	CTS12-1001	Weldment, Clamp, CAP	2
3	CTS12-0040	Cover, Hammer	1
4	CTS12-0075	Screw, Clamp, 7.62 L	4
5	CTS12-0500	Block, Clamp, Elastomeric H65SD2, Hitachi®	2
6	CTS12-0510	Block, Clamp, Elastomeric H65SD2, Hitachi®	2
7	15061000	Screw, Cap, 3/8-16 UNC x 1-1/4", Plated	2
8	16060000	Washer, Lock, 3/8", Plated	2

Replacement Parts Diagram Breaker Mount Assembly Makita® HM1317CB

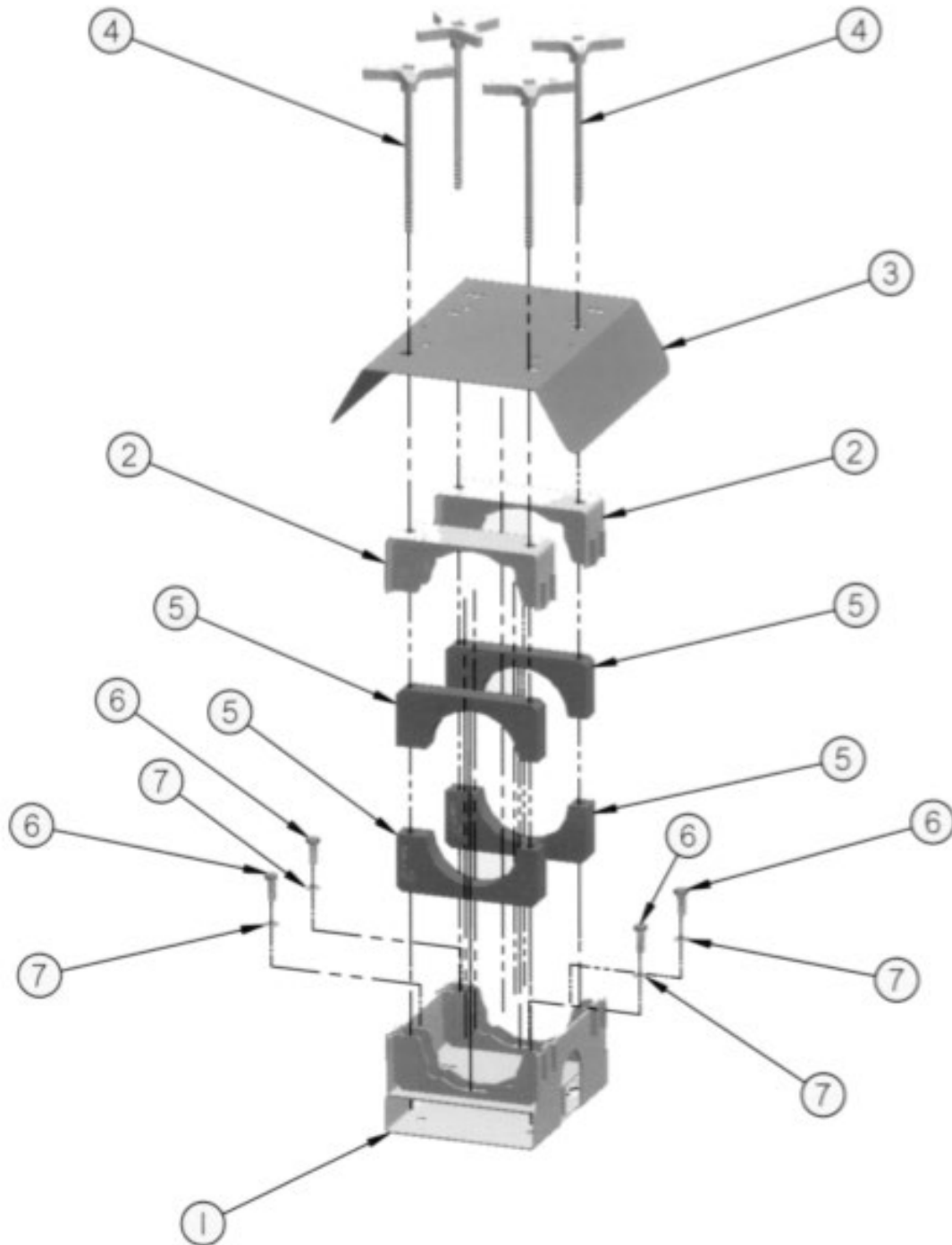

Replacement Parts Diagram
Breaker Mount Assembly
Makita® HM1317CB

Reference Number	Part Number	Description	Quantity
1	CTS12-1100	Weldment, Mount, Base	1
2	CTS12-1101	Weldment, Clamp, Cap	2
3	CTS12-0040	Cover, Hammer	1
4	CTS12-0070	Screw, Clamp, 7.08 L	4
5	CTS12-0490	Block, Clamp, Elatomeri c HMI317CB, Makita®	4
6	15060800	Screw, Cap, 3/8-16 UNC x 1", Plated	4
7	16060000	Washer, Lock, 3/8", Plated	4

Replacement Parts Diagram Breaker Mount Assembly Makita® HM1500B

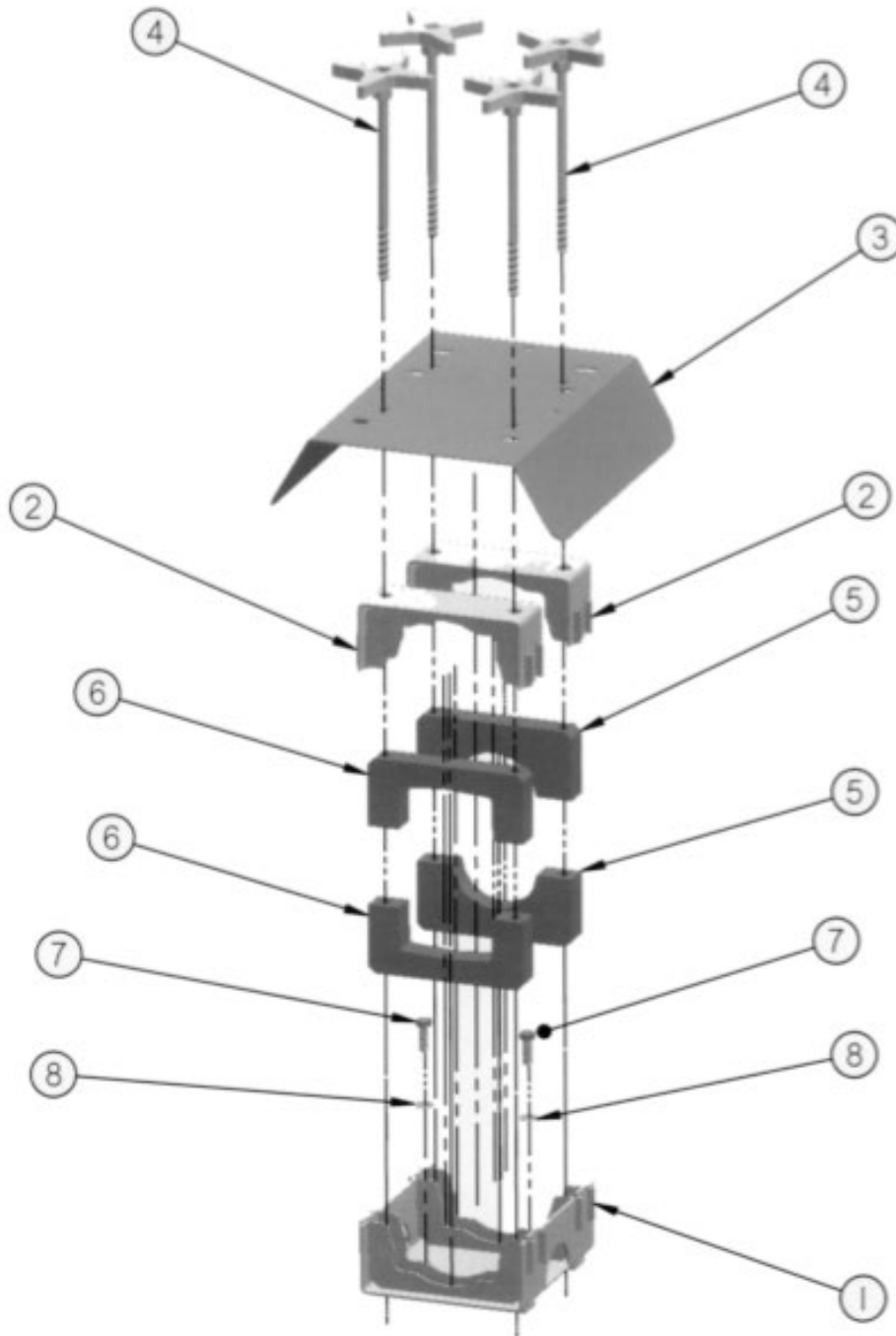

Replacement Parts Diagram
Breaker Mount Assembly
Makita® HM1500B

Reference Number	Part Number	Description	Quantity
1	CTS12-1000	Weldment, Mount, Base	1
2	CTS12-1001	Weldment, Clamp, Cap	2
3	CTS12-0040	Cover, Hammer	1
4	CTS12-0075	Screw, Clamp, 7.62 L	4
5	CTS12-0310	Block, Clamp, Elastomeric HM1500B, Makita®	2
6	CTS12-0300	Block, Clamp, Elastomeric HM1500B, Makita®	2
7	15061000	Screw, Cap, 3/8-16 UNC x 1-1/4", Plated	2
8	16060000	Washer, Lock, 3/8", Plated	2

Replacement Parts Diagram Decals

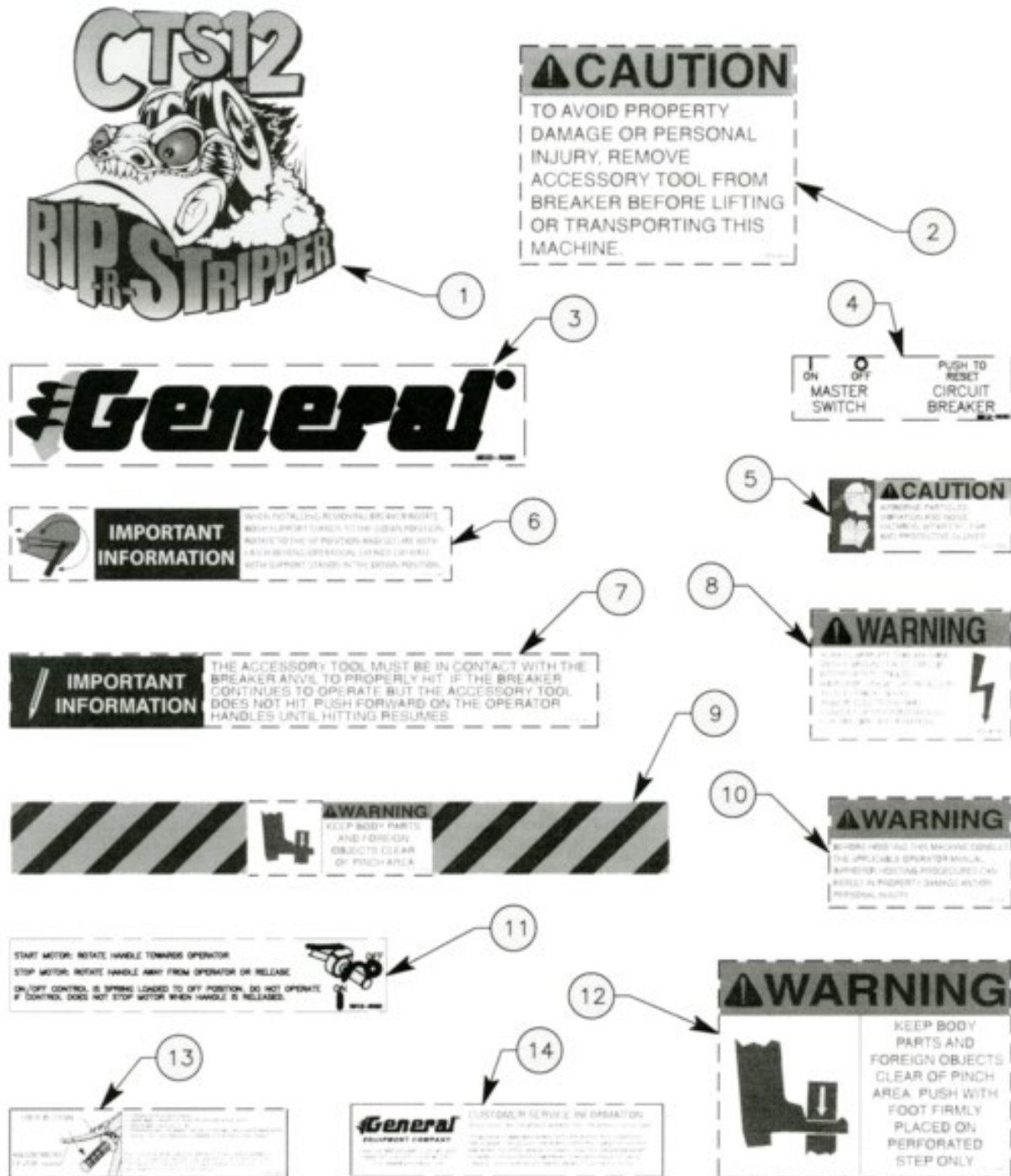

Replacement Parts Diagram Decals

Reference Number	Part Number	Description	Quantity
1	CTS-5050	Decal, RIP-R-STRIPPER	2
2	CTS12-5010	Decal, Caution, Transport	1
3	GECD-5020	Decal, General	1
4	SG12-5030	Decal, Switch	1
5	FCS5-5020	Decal, Caution, Read	1
6	CTS12-5060	Decal, Kickstand	2
7	CTS12-5070	Decal, Operation	1
8	FCS16-5030	Decal, Warning, Electrical Shock	1
9	CTS12-5040	Decal, Warning, Feet Clear	2
10	CS8-5050	Decal, Warning, Hoisting	2
11	SG12-5020	Decal, Starting	1
12	CTS12-5030	Decal, Warning, Pinch, Point	1
13	CTS12-5020	Decal, Lever	1
14	SG24-5072	Decal, Assistance	1